

Clayton Steam Master

Advantages

The forced circulation helical coil design concept of the Clayton Steam generator produces outstanding benefits to the user

High efficiency

Very high efficiency is the most obvious benefit that comes from small sizes because of low radiation and convection heat losses, which results in low running costs.

Small size

Compact design means that minimal space is required for a complete Clayton boiler house. For a new installation building costs are reduced and in an existing factory a Clayton system can easily be fitted into the available area and the low weight even permits location on an upper floor level.

Rapid Start

Start up from a completely cold condition is five minutes. The warm up fuel is minimised and the unit can be switched off when the operator leaves at the end of the working day. The Clayton Steam Master is therefore also ideal when used as an auxiliary or standby boiler.

Safety

It is not possible to have a steam explosion. This is a danger associated with low water level in other types of boiler that store a large volume of hot water. The Clayton Steam generator does not have a water level and does not store a large volume of water so the danger is completely eliminated.

5 Year Warranty

The Clayton Steam Master is of an extremely robust construction suitable for industrial environments. This is why we are able to offer a five year guarantee on pressure parts.

Rapid Response

Extremely rapid response to changes in the demand for steam is inherent in the forced circulation design. A Clayton Steam generator will speedily ramp up and run at maximum steam output continuously without faltering.

Low Blowdown

Blowdown which is necessary to prevent the build up of impurities in all boiler systems is extremely small with the Clayton design. This saves fuel, saves chemicals and saves water.

Easy Operation By Touchscreen

Very easy handling by touch screen panel, where appear handling instructions, spare part lists, instruction manuals, training video, etc.

Unattended Operation

Because of the inherent safety and automatic systems all Clayton Steam generators can run without operator attendance for up to a period of one week. For make the whole boiler room suitable for attended operation, the 'Unattended boiler room package' is needed.

Low Maintenance

One of the practical benefits of the simple design concept is that maintenance requirements are minimal. In addition all of the components have been developed and improved over many years to make the Clayton Steam Master the most reliable steam boiler available today

Our success is built on the expertise of our staff who are committed to providing exceptional levels of customer service and support. The Clayton lifetime customer care is second to none and our dedicated service team is ready to assist with immediate technical support that is available 24 hours a day - 7 days a week.

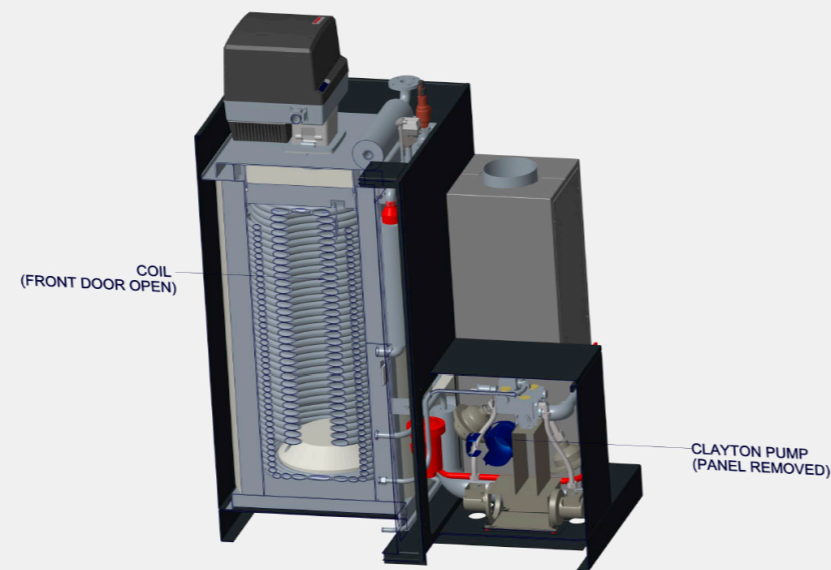

Headquarters
for Europe
Middle East & Africa

CLAYTON OF BELGIUM nv

Rijksweg 30 - 2880 Bornem Tel.: + 32 (0)3 890 57 00 - Fax: + 32 (0)3 890 57 01
www.clayton.be - sales@clayton.be

USA World Headquarters	www.claytonindustries.com
BELGIUM Headquarters EMEA	www.clayton.be
FRANCE	www.clayton.fr
UK	www.claytonindustries.co.uk
MEXICO	www.clayton.com.mx
GERMANY	www.clayton-deutschland.de
SPAIN	www.clayton.es
THE NETHERLANDS	www.clayton.be



Clayton
STEAM MASTER

Clayton Steam Master

Clayton Steam Master

The Clayton Steam Master represents progress that can only be achieved after more than 80 years' operating experience of advanced steam boiler technology.

This is the latest product of our progressive research and development programmes and is the next generation Clayton Steam Generator for steam duties in the range up to 700 kg/h.



CSM45
from 180 to 700kg/h

CSM30
from 120 to 470kg/h

CSM15
from 60 to 230kg/h

Technical Description

All three sizes of Clayton Steam Master can run on either oil or gas. Gas fired units have fully modulating output control from 100% to 20% and oil fired units have the Clayton three step modulating control. Electrical supply required is only 220V single phase with a power rating that is less than a domestic electric kettle.

Steam is produced by a heated, once-through, water tube coil that is the heart of the design. Operating steam pressure is 7 barg. An additional feature is the unique Clayton glandless, packless water pump that has been proven to give outstanding performance, response and reliability. The Clayton Steam Master is of an extremely robust construction suitable for industrial environments. This is why we are

able to offer a five year guarantee on pressure parts.

The Clayton 'easy start' system is a straightforward means of putting the unit into service. The user-friendly touch screen gives operator

prompts and self-diagnostics with immediate visual indication of status. Information is clearly displayed to show that your steam supply is working perfectly. The standard unit is fitted with safeguards to permit unattended operation for up to 1 week.

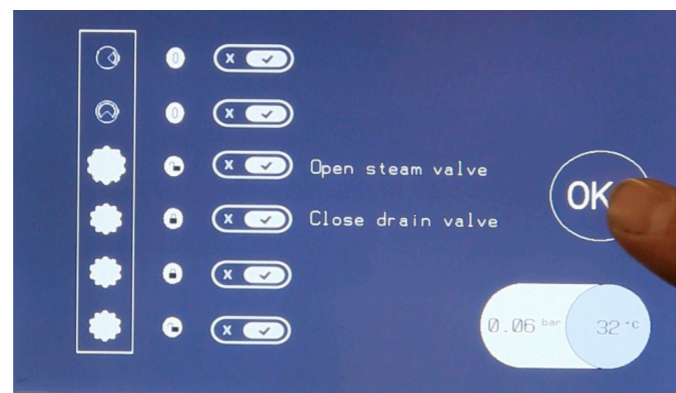

STEAM MASTER

Easy to Operate

Touchscreen Control

High Efficiency

Five Year Warranty

Fully Modulating

Low Emissions

Safe

Runs Without Supervision

Short Start-up Time

Reliable

Low Maintenance

Approximate Overall dimensions

		CSM15	CSM30	CSM45	waterskid
Length	mm	1500	1600	1800	1525
Width	mm	1350	1350	1350	1000
Height	mm	1710	2060	2460	2250
Transport Height without burner and safety valve	mm	1710	2010	2230	
Maintenance height above burner	mm	250	250	250	



STEAM MASTER

Positioning of water preparation package

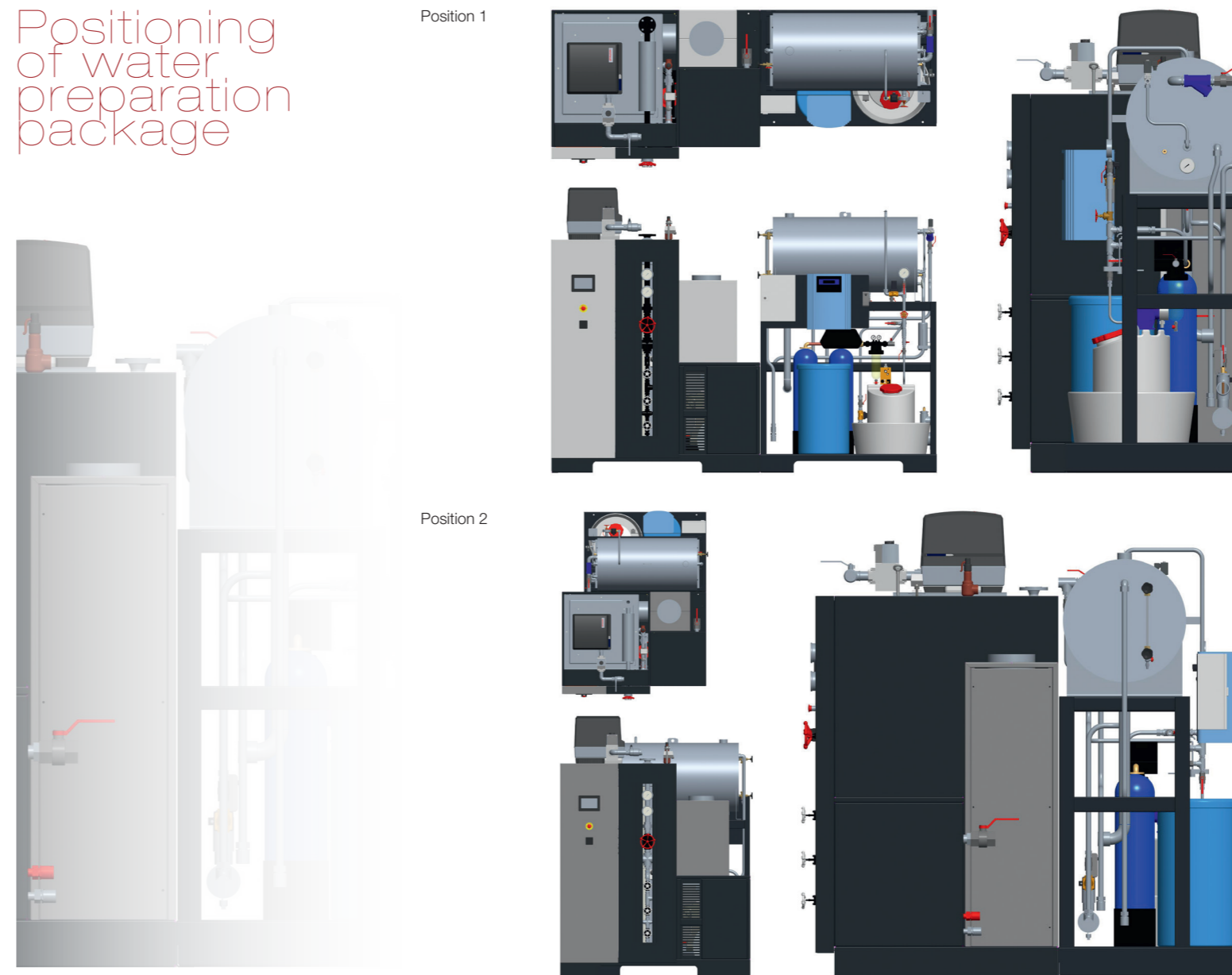

Position 1

Position 2

Option Packages

The six option packages that are available allow configuration of the Clayton Steam Master to suit your particular needs.

Fuel Saving Package

To reduce fuel consumption and significantly lower annual running costs, by adding a finned tube economiser section.

Steam Quality Package

Integrated high efficiency steam separator, steam trap and automatic blowdown valve. This package can be supplied with the unit or easily fitted at a later date.

Water Preparation Package

Frame mounted and interconnected horizontal hotwell, chemical dosing, blowdown cooling, duplex water softener and sample cooler. To be positioned beside Clayton Steam Master. Connection between Clayton Steam Master and Water Preparation Package is done by a flexible hose, also delivered by Clayton.

Unattended Boiler Room Package

For unattended operation of the boiler room for up to one week the Unattended Boiler Room Package includes a conductivity monitor and hardness monitor mounted on the water preparation package, above.

Remote Communication Package

For additional peace of mind while the unit is operating unattended. Sending messages on the running status to a mobile device so you are in constant communication with your steam boiler plant at all times.

Automatic start/stop Package

Includes a back pressure regulator and uses a steam trap for unloading, so this option also requires the 'steam quality package' (see above).

SAVES FUEL - SAVES SPACE - SAVES TIME - SAVES MONEY