

DENTAL X-RAY

BELRAY II 097

**SERVICE
MANUAL**

(for 220V, 230V, 240V)

 **Belmont[®]**

INDEX

	page
SECTION 1 : TECHNICAL DATA	
[1] ELECTRICAL AND RADIATION DATA	2
[2] PHYSICAL DIMENSIONS	3
[3] TUBE HEAD THERMAL CHARACTERISTICS	5
SECTION 2 : OPERATION INSTRUCTION	
[1] LAYOUT OF CONTROL BOX	6
[2] FUNCTION OF CONTROLS	7
[3] OPERATING PROCEDURES	9
[4] OPTIONAL HAND EXPOSURE SWITCH.....	9
[5] ALTERATION OF SETTING	10
SECTION 3 : DESCRIPTION FOR FUNCTIONS	
[1] GENERAL	15
[2] AUTOMATIC VOLTAGE REGULATOR	16
[3] PRIMARY CIRCUIT OF HIGH VOLTAGE TRANSFORMER	16
[4] PRIMARY CIRCUIT OF FILAMENT TRANSFORMER	17
[5] AUTOMATIC TUBE CURRENT CONTROL	17
SECTION 4 : ADJUSTMENT	
[1] AVR VOLTAGE	18
[2] INSPECTION OF TUBE CURRENT	20
[3] ADJUSTMENT OF TUBE CURRENT	21
[4] ADJUSTMENT OF LINE VOLTAGE MEASUREMENT ERROR	22
SECTION 5 : PERIODIC INSPECTION AND ADJUSTMENT	
[1] ELECTRICAL INSPECTION AND ADJUSTMENT	23
[2] MECHANICAL INSPECTION	24
SECTION 6 : ERROR CODE	25
SECTION 7 : TROUBLE SHOOTING	27
SECTION 8 : REPLACEMENT OF COMPONENT	
[1] CONTROL BOX	29
[2] TUBE HEAD	29
SECTION 9 : CIRCUIT DIAGRAM	30

SECTION 1 : TECHNICAL DATA

[1] ELECTRICAL AND RADIATION DATA

1. Nominal focal spot value -----0.7 (IEC60336)
2. Rated peak tube potential ----- 70 kV
3. Rated tube current ----- 4 mA / 7 mA selectable
4. Maximum rated peak tube potential ----- 70 kV

Rated Line Voltage	[Vac]	220	230	240
Minimum Line Voltage	[Vac]	198	207	216
Maximum Line Voltage	[Vac]	242	253	264
Rated Line Power (Momentary rating)	[kVA]	0.8	0.8	0.8
Rated Line Current at 7mA	[Aac]	3.4	3.4	3.4
Maximum Line Current at 7mA	[Aac]	3.7	3.7	3.7
(Internal Resistance	[Ω])	(1.27max)	(1.33max)	(1.38max)
Range of Line Voltage Regulation	[%]	0 ~ 2	0 ~ 2	0 ~ 2

6. Power line frequency ----- 50 / 60Hz, Single Phase
7. Line power (Long term rating) ----- 12VA
8. Exposure time ----- 0.02 ~ 3.2 sec.(ON and OFF are zero crosseed)
9. Timer accuracy ±1 pulse (= 1/50 sec. or 1/60 sec.)
10. Inherent filtration----- 1.7 mm Al Equivalent
11. Added filtration ----- 0.5 mm Al
12. Minimum filtration permanently in useful beam ---- 2.2 mm Al Equivalent at 70 kV(peak)
13. Nominal roentgen output

	4 mA	7 mA	
a. Distal end of regular cone -----	4.2mGy/sec.	7.1mGy/sec.	±40%
b. Distal end of long cone -----	2.4mGy/sec.	3.3mGy/sec.	±40%
14. Cone

	Source to skin distance	Field size
a. Regular cone.....	204 mm	58mm dia., circular
b. Long cone (Option)	305 mm	58mm dia., circular
15. Leakage technique factor 70 kV(peak), 494 mAs at 1 hour
16. Duty cycle 1 : 50 (0.5 sec. exposure with 25 sec. interval)
17. Source to the base of cone distance 81 mm
18. Reference current time product..... 22.4 mAs (70 kV(peak), 7 mA, 3.2 sec.)
19. Maximum earth leakage current 0.5 mA
20. Tolerance of the focal spot marking..... ±1 mm
21. Target angle and material 16 ± 1°, Tungsten
22. Maximum anode heat content 4.3 kJ (6 kHU)
23. Maximum x-ray tube assembly heat content 150 kJ (210 kHU)
24. Nominal electrical output of H.V. Generator 0.36 kW at 70 kV, 7 mA
25. Measurement base of technique factors

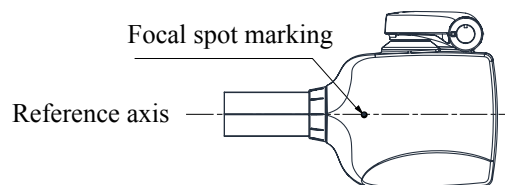

- a. Peak tube potential Peak tube potential of conducting half cycle
- b. Tube current Average of tube current during one cycle of line frequency
- c. Exposure time..... Impulses of power line frequency
- 26 Environmental condition for storage.....-20 ~ 70°C, 10 ~ 90%, 500 ~ 1060 hPa
27. Environmental condition for operation.....10 ~ 40°C, 30 ~ 75%, 700 ~ 1060 hPa
28. Rotation angle of head Horizontal 0 ~ 600° , Vertical 0 ~ 300°
29. Service Life..... 10 Years

[2] PHYSICAL DIMENSIONS

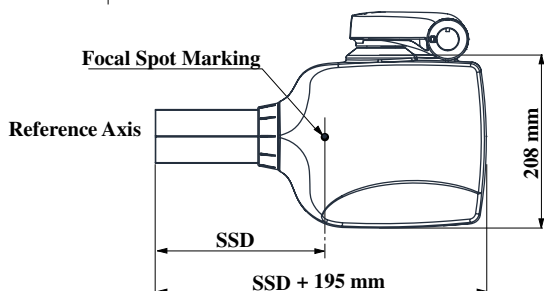
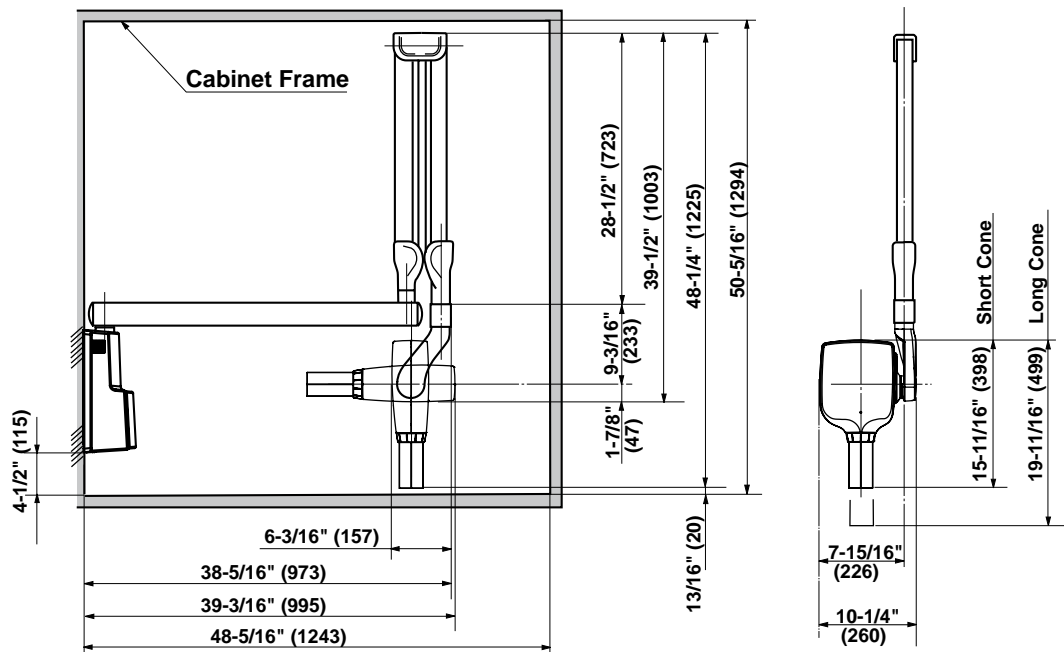
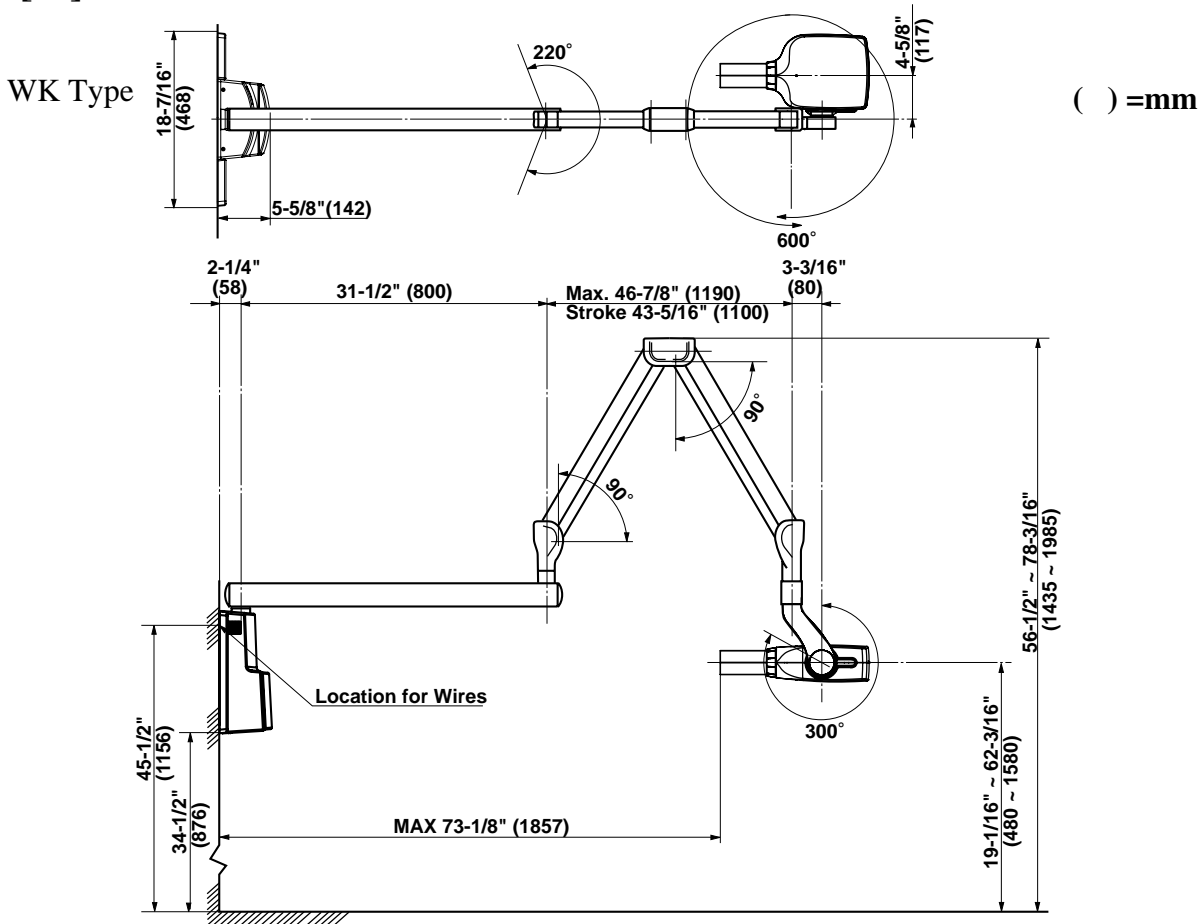

SSD (Source to Skin Distance) :

- Regular cone-----8 inches (203 mm)
- Long cone-----12 inches (305mm)

Fig.1 Dimensions

FM Type

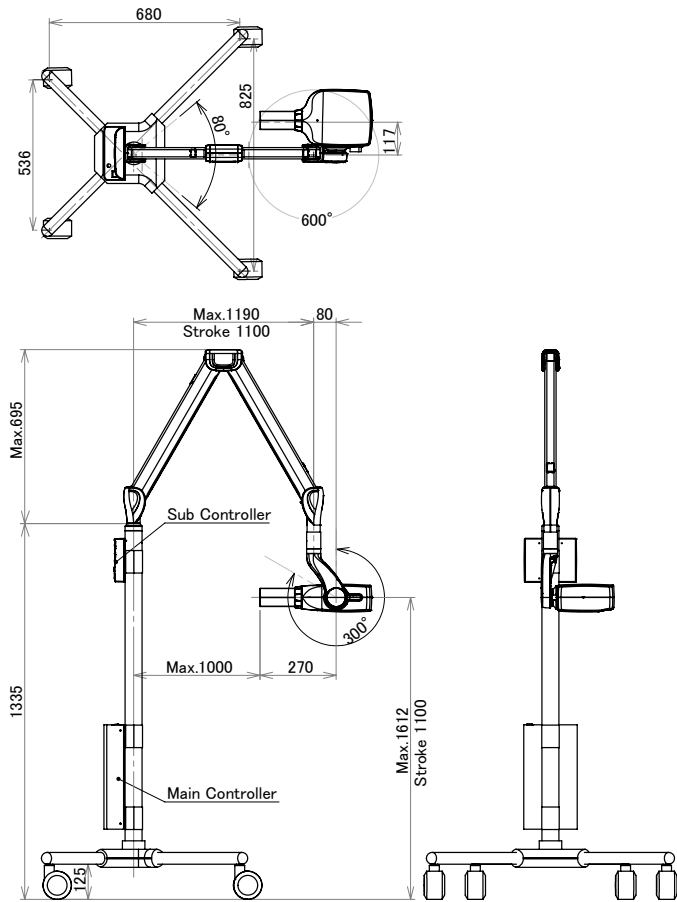

FK1/FK2 Type

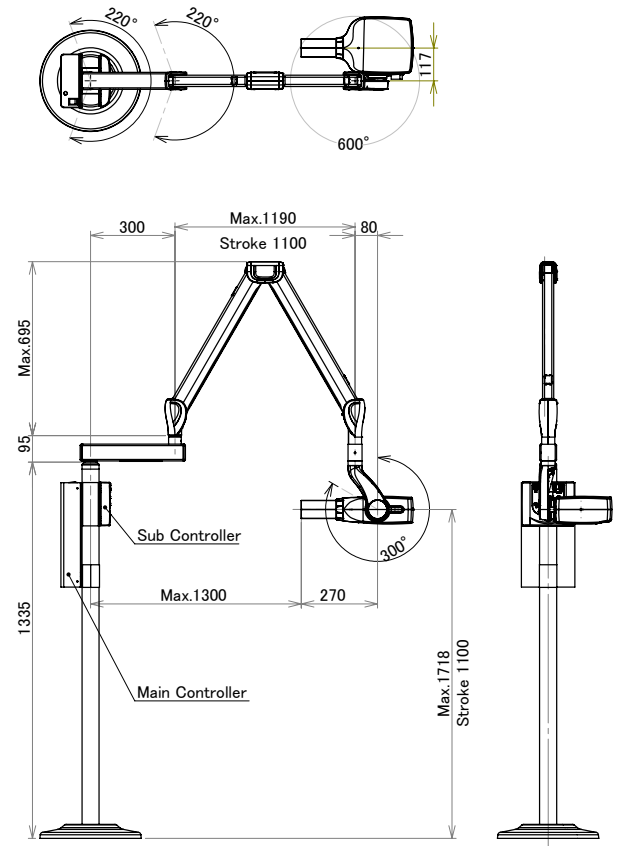

RK Type

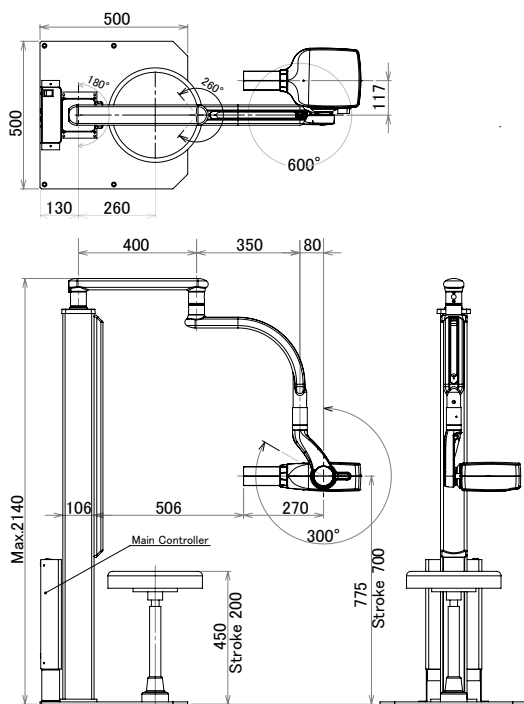

CK Type

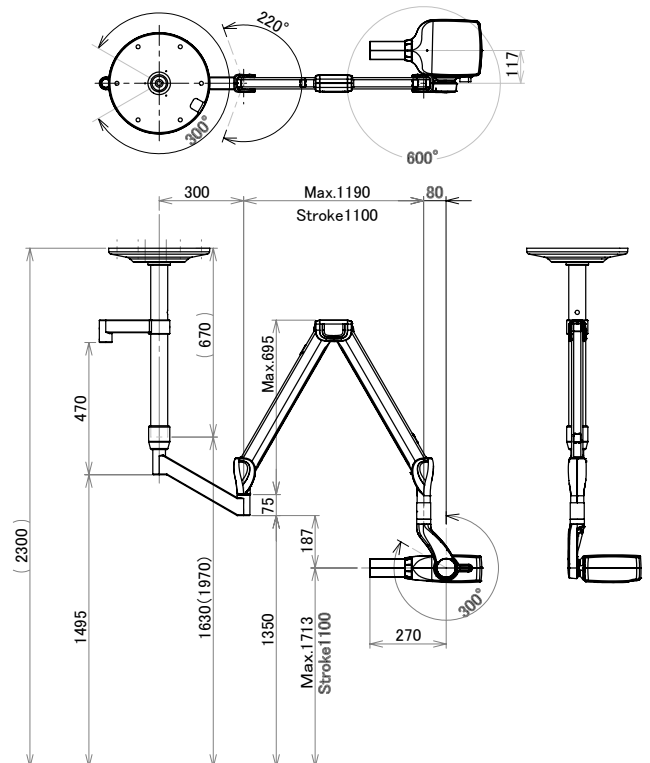

Fig.1-6 Dimensions

[3] TUBE HEAD THERMAL CHARACTERISTICS

A. Interval between each exposure

The temperature inside of the tube head rises when an exposure is made. The value of the heat generated is measured in Heat Units (HU), which is the product of tube potential, tube current and exposure time. Excessive heat will accumulate inside of the tube head if the x-ray is used without a proper cool down interval between each exposure. The excessive heat may damage the x-ray tube, high voltage generator or both.

B. Duty cycle

A cool down interval of 50 seconds or more must be allowed between each 1 second exposure. (a 25 second cool down must be allowed between each 0.5 second exposure.) This will avoid the accumulation of excess heat and prolong the tube head life.

C. Tube head cooling curve

1. Tube housing cooling curve

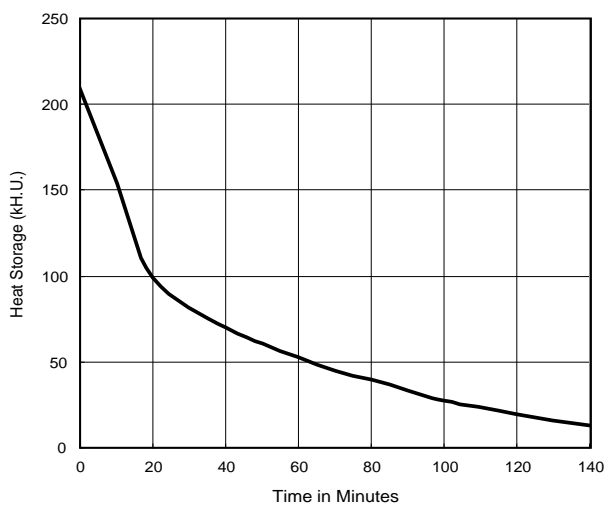

2. Anode thermal characteristics

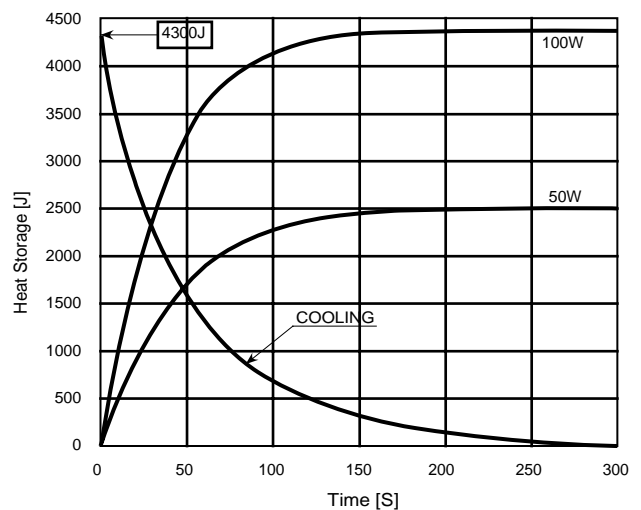

3. Maximum rating chart

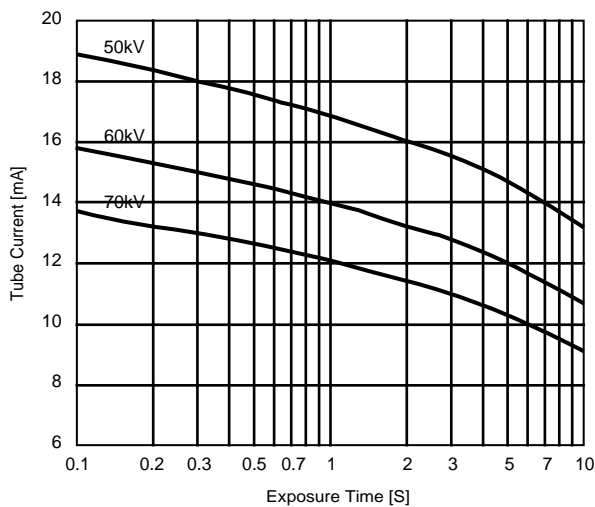

SECTION 2 : OPERATION INSTRUCTIONS

[1] LAYOUT OF CONTROLLERS

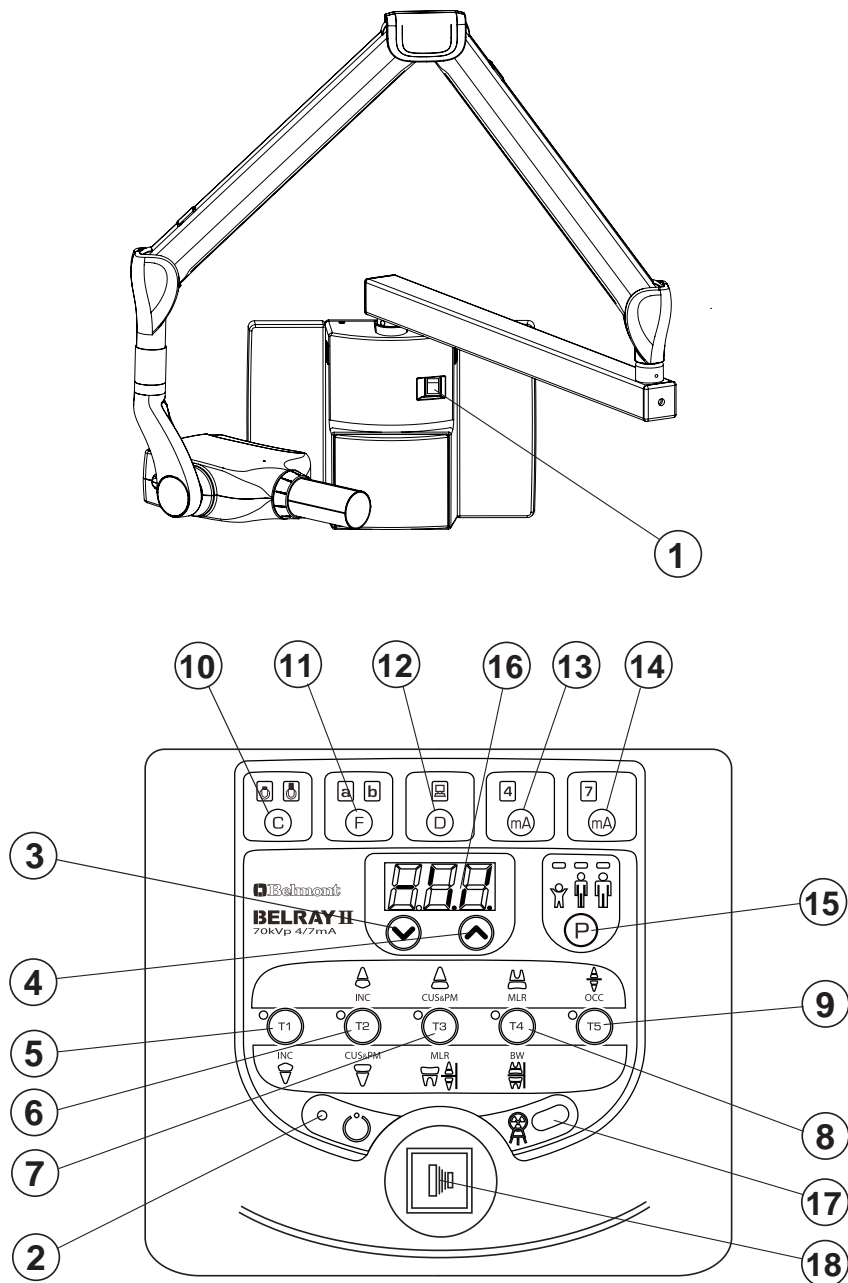

Fig.2 Major Components and Control Identification

- | | |
|---|------------------------------------|
| (1) Main Power Switch | (10) Cone Type Selection Switch |
| (2) Ready Light | (11) Film Speed Selection Switch |
| (3) Exposure Time Adjusting Switch (Down) | (12) Digital Imaging Switch |
| (4) Exposure Time Adjusting Switch (Up) | (13) 4mA Selection Switch |
| (5) Tooth Selection Switch (T1) | (14) 7mA Selection Switch |
| (6) Tooth Selection Switch (T2) | (15) Patient Size Selection Switch |
| (7) Tooth Selection Switch (T3) | (16) Exposure Time Display Window |
| (8) Tooth Selection Switch (T4) | (17) Exposure Warning Light |
| (9) Tooth Selection Switch (T5) | (18) Exposure Switch |

[2] FUNCTION OF CONTROLS

(1) Main Power Switch

Pushing the upper side of this switch to the ON position energizes the x-ray unit. (Ready light and pre-select light for cone type, film or digital, mA, and patient size illuminate.)

It is recommended to keep this switch OFF when the unit is not in use, in order to prevent an accidental exposure.

IMPORTANT : To prevent the risk of an accidental exposure, push the lower side of this switch to the OFF position, when the unit is not in use.

(2) Ready Light

This light illuminates when the line voltage is within operable range. When this light is not on, exposure can not be made.

(3)(4) Exposure Time Adjusting Switches

By momentarily pushing the (⤴ or ⤵) switch, the exposure time displayed increases (or decreases) by one increment. By keeping the switch depressed more 2 sec., the exposure time displayed increases (or decreases) continuously until the switch is released.

Model 097 has the following 23 exposure time settings :

0.00, 0.02, 0.03, 0.04, 0.05, 0.06, 0.08, 0.10, 0.13, 0.16, 0.20, 0.25, 0.32, 0.40
0.50, 0.63, 0.80, 1.00, 1.25, 1.60, 2.00, 2.50, 3.20 (sec.)

(5) ~ (9) Tooth Selection Switches (T1 ~ T5)

Pushing one of these switches sets the exposure time automatically for the following (10) ~ (15).

(5) T1 : Incisor of Mandible

(6) T2 : Incisor of Maxilla, Cuspid & Premolar of Mandible

(7) T3 : Cuspid & Premolar of Maxilla, Molars of Mandible, Bite Wing

(8) T4 : Molar of Maxilla, Bite Wing Molars

(9) T5 : Occlusal

If the T1 switch (5) is depressed more than 3 sec., unit goes into “ Lock Mode”.

In lock mode, the only functional switch is the power switch. To exit from the lock mode, depress the T1 switch more than 3 sec. again.

(10) Cone Type Selection Switch

Depressing this switch for more than 2 sec. selects the cone type : 8” standard cone or 12” optional long cone. (If the optional rectangular cone is to be used, select the 8” cone setting.)

(11) Film Speed Selection Switch

a. BELRAY II has 16 film speed settings : (F.00 ~ F.15)

Two speed settings are pre-set at the factory (a & b) and can be selected with (11).

a = Film speed No. F.09 (equivalent to ISO speed group “ D” or Kodak Ultra-Speed film)

b = Film speed No. F.04 (equivalent to ISO speed group “ F/E” or Kodak InSight film)

b. Pushing this switch momentarily displays the selected film speed setting in the **Exposure Time Display Window** (16).

Depressing this switch for more than 2 sec. changes the film type being selected.

c. If the **Digital Imaging Switch** (12) is depressed, both of the film speed indicating light (a & b) are turned off.

(12) Digital Imaging Switch

If a digital imaging system is used, shorter exposure time is often required. BELRAY II has 16 speeds for digital imaging : (d.00 ~ d.15). Pushing this switch momentarily displays the speed being selected in the **Exposure Time Display Window** (16). With the factory speed setting d.06, the exposure time becomes half of F.06 setting.

TABLE 1. Speed Setting and Exposure Time (Regular Cone) [unit : sec.]

Speed Setting	mA	Child					Adult					Obese				
		T1	T2	T3	T4	T5	T1	T2	T3	T4	T5	T1	T2	T3	T4	T5
F.09	4	0.20	0.32	0.40	0.50	0.80	0.32	0.50	0.63	0.80	1.25	0.40	0.63	0.80	1.00	1.60
	7	0.10	0.20	0.20	0.32	0.40	0.20	0.32	0.40	0.50	0.63	0.20	0.40	0.40	0.63	0.80
F.04	4	0.08	0.13	0.16	0.20	0.32	0.13	0.20	0.25	0.32	0.50	0.16	0.25	0.32	0.40	0.63
	7	0.05	0.08	0.10	0.13	0.16	0.08	0.13	0.16	0.20	0.32	0.10	0.16	0.20	0.25	0.32
d.06	4	0.06	0.10	0.10	0.16	0.20	0.10	0.16	0.20	0.25	0.40	0.10	0.20	0.25	0.32	0.40
	7	0.03	0.05	0.06	0.08	0.13	0.05	0.08	0.10	0.13	0.20	0.06	0.10	0.13	0.16	0.25

TABLE 2. Speed Setting and Exposure Time (Long Cone) [unit : sec.]

Speed Setting	mA	Child					Adult					Obese				
		T1	T2	T3	T4	T5	T1	T2	T3	T4	T5	T1	T2	T3	T4	T5
F.09	4	0.40	0.63	0.80	1.00	1.60	0.63	1.25	1.25	2.00	2.50	0.80	1.25	1.60	2.00	3.20
	7	0.25	0.40	0.50	0.63	1.00	0.40	0.63	1.80	1.00	1.60	0.50	0.80	1.00	1.25	2.00
F.04	4	0.16	0.25	0.32	0.50	0.63	0.25	0.50	0.50	0.80	1.00	0.32	0.50	0.63	1.00	1.25
	7	0.10	0.16	0.20	0.25	0.40	0.16	0.25	0.32	0.40	0.63	0.20	0.32	0.40	0.50	0.80
d.06	4	0.13	0.20	0.25	0.32	0.50	0.20	0.32	0.40	0.50	0.80	0.25	0.40	0.50	0.63	1.00
	7	0.06	0.13	0.13	0.20	0.25	0.10	0.20	0.25	0.32	0.40	0.13	0.25	0.25	0.40	0.50

(13) 4mA Selection Switch

By momentarily depressing this switch, the tube current is set at 4mA.

When Film switch is depressed, the tube current setting will be automatically changed to 7mA.

(14) 7mA Selection Switch

By momentarily depressing this switch, the tube current is set at 7mA.

When Digital switch is depressed, the tube current setting will be automatically changed to 4mA.

(15) Patient Size Selection Switch

This switch alters the selection of patient type/size to be radiographed (child→adult→Obese→child) and sets the exposure time automatically.

NOTE : Setting or adjusting the exposure time manually (with \triangle or ∇ switch) supersedes (5) ~ (15) functions.

(16) Exposure Time Display Window

This window displays the selected exposure time. If an abnormal condition exists or a malfunction occurs, an Error Code is displayed. (See Section 6 : **ERROR CODE**)

(17) Exposure Warning Light

Illumination of this light indicates the unit is producing x-radiation.

(18) Exposure Switch

This switch initiates radiographic exposure. When making an exposure, depress and hold this switch until the **Exposure Warning Light** (17) and the audible warning shut off. Failure to keep this switch depressed will result in the premature termination of the exposure and error code E.00 will be displayed in **Exposure Time Display Window** (16).

[3] OPERATING PROCEDURES

1. Turn ON the Main Power Switch (1).
2. Confirm that Ready Light (2) is illuminated.

NOTE : The ready light will not illuminate unless the incoming line voltage is correct and within the x-ray's operable range.

3. Select the appropriate tooth type (5) ~ (9), and confirm the pre-selected conditions (cone type, film or digital, mA and patient size) are suitable for exposure.

NOTE : To manually set the exposure time, depress either of the manual Exposure Time Adjust Switches (⤴ or ⤵) until the desired exposure time appears in the Exposure Time Display Window (16). While the unit is in manual mode, other selection switches (5) ~ (15) do not affect exposure time. (All of the tooth selection lights are off.) To return to the automatic exposure time selection mode, depress any one of Tooth Selection Switches (5) ~ (9).

4. Depress the Exposure Switch (8). When the Exposure Switch is depressed, the Exposure Warning Light (17) illuminates and the audible warning sounds. Do not release the Exposure Switch until the Exposure Warning Light and audible warning automatically shut off. Failure to keep the switch depressed will result in exposure being terminated prematurely.
5. To continue to radiograph other teeth, just select appropriate Tooth Selection Switches (5) ~ (9).

IMPORTANT : To protect x-ray tubehead from heat accumulation, wait for a time interval that is equal to 50 times the selected exposure time before making additional exposures. (Example : a 25 sec. wait is necessary between exposures that are 0.5 sec. in duration.)

6. Turn OFF the Main Power Switch (1) in order to prevent accidental exposure when the unit is not in use.

NOTE : If the unit is left over 8 min. without being operated and Main Power Switch (1) is kept on, figure "1" runs through the Exposure Time Display Window (16). This does not mean that malfunction of the unit has occurred ; this is an energy saving feature. The unit returns to ready condition by pressing any one of the switches, except the Exposure Switch (18).

[4] OPTIONAL HAND EXPOSURE SWITCH

An optional hand exposure switch can be connected to the sub controller. Since this exposure switch has a coiled cord, operators can stand in the most suitable position for operation.

As controller has separate connector for this exposure switch, both exposure switch (18) on the front panel of sub controller and this hand exposure switch can be used.

If local code prohibits use of both, disconnect the connector of either switch.

[5] ALTERATION OF SETTINGS

(1) SPEED SETTING FOR FILM AND DIGITAL IMAGING

A. FILM SPEED

Prior to shipment of the x-ray from the factory, the following two film speeds are programmed to be selected by the Film Speed Selection Switch.

a = Film speed F.09 (equivalent to ISO speed group "D", or Kodak Ultra-speed Film)

b = Film speed F.04 (equivalent to ISO speed group "F/E", or Kodak InSight Film)

In addition to these two speeds, BELRAY II 097 x-ray can provide 16 different film speeds (F.00 ~ F.15) and any two of them can be programmed for easy selection. If the doctor uses a different film speed, or prefers darker (or lighter) radiographs, the new speed can be programmed as follows. Higher speed settings make films darker. If film speed is increased by 1, exposure time becomes 25 % longer.

1. Keep the 4mA selection switch and 7mA selection switch depressed simultaneously for more than 3 seconds. Release the switches if the ready light starts to flash.
2. Push F switch momentarily until the "a" light above the F switch illuminates. The exposure time display window shows the present film speed for "a" setting. (The factory default setting, F.09 should be displayed.) By depressing \odot or \ominus switch, increase or decrease film speed number until desired number for "a" setting is displayed.
3. To change the "b" setting from the factory default, F.05, push F switch momentarily until the "b" light illuminates. By depressing \odot or \ominus switch, increase or decrease film speed until the desired number for "b" setting is displayed.
4. Press **T1 switch** to store these settings, then turn the main power switch off.

B. SPEED FOR DIGITAL IMAGING

BELRAY II 097 x-ray has 16 speeds for digital imaging (d.00 ~ d.15). The factory setting is d.06 and with this setting the exposure time becomes half of F.06 setting.

As the sensitivity is different according to each manufacturer of digital imaging sensors, this setting should be adjusted. To get a darker image, increase the speed setting and to get a lighter image, decrease the speed setting. If the speed setting is increased by 1, exposure time becomes 12 % longer.

1. Keep 4mA selection switch and 7mA selection switch depressed simultaneously for more than 3 seconds. Release the switches if the ready light starts to flash.
2. Push D switch momentarily until the light above the D switch illuminates and the exposure time display window shows the present speed setting. (The factory default setting d.06 should be displayed.)
3. By depressing \odot or \ominus switch, increase or decrease speed until the desired number is displayed.
4. Press **T1 switch** to store these settings, then turn the main power switch off.

Table 3. Film number and exposure time in film mode (at 7mA with regular cone) (Unit : Sec.)

patient	Child					Adult					Obese				
	T1	T2	T3	T4	T5	T1	T2	T3	T4	T5	T1	T2	T3	T4	T5
F.00	0.02	0.04	0.04	0.06	0.08	0.04	0.06	0.08	0.10	0.13	0.04	0.08	0.08	0.13	0.16
F.01	0.03	0.04	0.05	0.08	0.10	0.04	0.08	0.08	0.10	0.16	0.05	0.08	0.10	0.13	0.20
F.02	0.03	0.05	0.06	0.08	0.13	0.05	0.08	0.10	0.13	0.20	0.06	0.10	0.13	0.16	0.25
F.03	0.04	0.06	0.08	0.10	0.16	0.06	0.10	0.13	0.16	0.25	0.08	0.13	0.16	0.20	0.32
F.04	0.05	0.08	0.10	0.13	0.16	0.08	0.13	0.16	0.20	0.32	0.10	0.16	0.20	0.25	0.32
F.05	0.05	0.08	0.10	0.13	0.20	0.08	0.16	0.16	0.25	0.32	0.10	0.16	0.20	0.32	0.40
F.06	0.06	0.10	0.13	0.16	0.25	0.10	0.16	0.20	0.25	0.40	0.13	0.20	0.25	0.32	0.50
F.07	0.08	0.13	0.16	0.20	0.32	0.13	0.20	0.25	0.32	0.50	0.16	0.25	0.32	0.40	0.63
F.08	0.10	0.16	0.20	0.25	0.40	0.16	0.25	0.32	0.40	0.63	0.20	0.32	0.40	0.50	0.80
F.09	0.10	0.20	0.20	0.32	0.40	0.20	0.32	0.40	0.50	0.63	0.20	0.40	0.40	0.63	0.80
F.10	0.13	0.20	0.25	0.32	0.50	0.20	0.40	0.40	0.63	0.80	0.25	0.40	0.50	0.63	1.00
F.11	0.16	0.25	0.32	0.40	0.63	0.25	0.40	0.50	0.63	1.00	0.32	0.50	0.63	0.80	1.25
F.12	0.20	0.32	0.40	0.50	0.80	0.32	0.50	0.63	0.80	1.25	0.40	0.63	0.80	1.00	1.60
F.13	0.25	0.40	0.50	0.63	0.80	0.40	0.63	0.80	1.00	1.60	0.50	0.80	1.00	1.25	1.60
F.14	0.25	0.50	0.50	0.80	1.00	0.40	0.80	0.80	1.25	1.60	0.50	1.00	1.00	1.60	2.00
F.15	0.32	0.50	0.63	0.80	1.25	0.50	0.80	1.00	1.60	2.00	0.63	1.00	1.25	1.60	2.50

Table 4. Film number and exposure time in film mode (at 4mA with regular cone) (Unit : Sec.)

patient	Child					Adult					Obese				
	T1	T2	T3	T4	T5	T1	T2	T3	T4	T5	T1	T2	T3	T4	T5
F.00	0.04	0.06	0.08	0.10	0.16	0.06	0.10	0.13	0.16	0.25	0.08	0.13	0.16	0.20	0.32
F.01	0.05	0.08	0.10	0.13	0.20	0.08	0.13	0.16	0.20	0.32	0.10	0.16	0.20	0.25	0.40
F.02	0.06	0.10	0.10	0.16	0.20	0.10	0.16	0.20	0.25	0.32	0.10	0.20	0.20	0.32	0.40
F.03	0.06	0.10	0.13	0.16	0.25	0.10	0.16	0.20	0.32	0.40	0.13	0.20	0.25	0.32	0.50
F.04	0.08	0.13	0.16	0.20	0.32	0.13	0.20	0.25	0.32	0.50	0.16	0.25	0.32	0.40	0.63
F.05	0.10	0.16	0.20	0.25	0.40	0.16	0.25	0.32	0.40	0.63	0.20	0.32	0.40	0.50	0.80
F.06	0.10	0.20	0.25	0.32	0.40	0.20	0.32	0.40	0.50	0.80	0.25	0.40	0.50	0.63	0.80
F.07	0.13	0.25	0.25	0.40	0.50	0.20	0.40	0.40	0.63	0.80	0.25	0.50	0.50	0.80	1.00
F.08	0.16	0.25	0.32	0.40	0.63	0.25	0.40	0.50	0.63	1.00	0.32	0.50	0.63	0.80	1.25
F.09	0.20	0.32	0.40	0.50	0.80	0.32	0.50	0.63	0.80	1.25	0.40	0.63	0.80	1.00	1.60
F.10	0.25	0.40	0.50	0.63	1.00	0.40	0.63	0.80	1.00	1.60	0.50	0.80	1.00	1.25	2.00
F.11	0.25	0.50	0.63	0.80	1.00	0.50	0.80	1.00	1.25	1.60	0.63	1.00	1.25	1.60	2.00
F.12	0.32	0.50	0.63	1.00	1.25	0.50	1.00	1.00	1.60	2.00	0.63	1.25	1.25	2.00	2.50
F.13	0.40	0.63	0.80	1.00	1.60	0.63	1.00	1.25	1.60	2.50	0.80	1.25	1.60	2.00	3.20
F.14	0.50	0.80	1.00	1.25	2.00	0.80	1.25	1.60	2.00	3.20	1.00	1.60	2.00	2.50	*
F.15	0.63	1.00	1.25	1.60	2.50	1.00	1.60	2.00	2.50	*	1.25	2.00	2.50	3.20	*

("*" in the table denotes that a tube current setting is automatically switched and set at the most appropriate time.)

Table 5. Film number and exposure time in film mode (at 7mA with long cone) (Unit : Sec.)

patient teeth	Child					Adult					Obese				
	T1	T2	T3	T4	T5	T1	T2	T3	T4	T5	T1	T2	T3	T4	T5
F.00	0.05	0.08	0.10	0.13	0.20	0.08	0.13	0.16	0.20	0.32	0.10	0.16	0.20	0.25	0.40
F.01	0.06	0.10	0.10	0.16	0.20	0.10	0.16	0.20	0.25	0.32	0.10	0.20	0.20	0.32	0.40
F.02	0.06	0.10	0.13	0.20	0.25	0.10	0.20	0.20	0.32	0.40	0.13	0.25	0.25	0.40	0.50
F.03	0.08	0.13	0.16	0.20	0.32	0.13	0.20	0.25	0.32	0.50	0.16	0.25	0.32	0.40	0.63
F.04	0.10	0.16	0.20	0.25	0.40	0.16	0.25	0.32	0.40	0.63	0.20	0.32	0.40	0.50	0.80
F.05	0.10	0.20	0.25	0.32	0.40	0.20	0.32	0.40	0.50	0.80	0.25	0.40	0.50	0.63	0.80
F.06	0.13	0.25	0.25	0.40	0.50	0.25	0.40	0.50	0.63	0.80	0.25	0.50	0.50	0.80	1.00
F.07	0.16	0.25	0.32	0.40	0.63	0.25	0.50	0.50	0.80	1.00	0.32	0.50	0.63	0.80	1.25
F.08	0.20	0.32	0.40	0.50	0.80	0.32	0.50	0.63	0.80	1.25	0.40	0.63	0.80	1.00	1.60
F.09	0.25	0.40	0.50	0.63	1.00	0.40	0.63	0.80	1.00	1.60	0.50	0.80	1.00	1.25	2.00
F.10	0.32	0.50	0.63	0.80	1.00	0.50	0.80	1.00	1.25	2.00	0.63	1.00	1.25	1.60	2.00
F.11	0.32	0.63	0.63	1.00	1.25	0.50	1.00	1.00	1.60	2.00	0.63	1.25	1.25	2.00	2.50
F.12	0.40	0.63	0.80	1.00	1.60	0.63	1.00	1.25	1.60	2.50	0.80	1.25	1.60	2.00	3.20
F.13	0.50	0.80	1.00	1.25	2.00	0.80	1.25	1.60	2.00	3.20	1.00	1.60	2.00	2.50	3.20
F.14	0.63	1.00	1.25	1.60	2.50	1.00	1.60	2.00	2.50	3.20	1.25	2.00	2.50	3.20	3.20
F.15	0.63	1.25	1.25	2.00	2.50	1.25	2.00	2.50	3.20	3.20	1.25	2.50	2.50	3.20	3.20

Table 6. Film number and exposure time in film mode (at 4mA with long cone) (Unit : Sec.)

patient teeth	Child					Adult					Obese				
	T1	T2	T3	T4	T5	T1	T2	T3	T4	T5	T1	T2	T3	T4	T5
F.00	0.08	0.13	0.16	0.20	0.32	0.13	0.20	0.25	0.32	0.50	0.16	0.25	0.32	0.40	0.63
F.01	0.10	0.16	0.20	0.25	0.40	0.16	0.25	0.32	0.40	0.63	0.20	0.32	0.40	0.50	0.80
F.02	0.13	0.20	0.25	0.32	0.50	0.20	0.32	0.40	0.50	0.80	0.25	0.40	0.50	0.63	1.00
F.03	0.13	0.25	0.25	0.40	0.50	0.25	0.40	0.50	0.63	0.80	0.25	0.50	0.50	0.80	1.00
F.04	0.16	0.25	0.32	0.50	0.63	0.25	0.50	0.50	0.80	1.00	0.32	0.50	0.63	1.00	1.25
F.05	0.20	0.32	0.40	0.50	0.80	0.32	0.50	0.63	0.80	1.25	0.40	0.63	0.80	1.00	1.60
F.06	0.25	0.40	0.50	0.63	1.00	0.40	0.63	0.80	1.00	1.60	0.50	0.80	1.00	1.25	2.00
F.07	0.32	0.50	0.63	0.80	1.25	0.50	0.80	1.00	1.25	2.00	0.63	1.00	1.25	1.60	2.50
F.08	0.32	0.63	0.63	1.00	1.25	0.63	1.00	1.25	1.60	2.00	0.63	1.25	1.25	2.00	2.50
F.09	0.40	0.63	0.80	1.00	1.60	0.63	1.25	1.25	2.00	2.50	0.80	1.25	1.60	2.00	3.20
F.10	0.50	0.80	1.00	1.25	2.00	0.80	1.25	1.60	2.00	3.20	1.00	1.60	2.00	2.50	*
F.11	0.63	1.00	1.25	1.60	2.50	1.00	1.60	2.00	2.50	*	1.25	2.00	2.50	3.20	*
F.12	0.80	1.25	1.60	2.00	2.50	1.25	2.00	2.50	3.20	*	1.60	2.50	3.20	*	*
F.13	0.80	1.60	1.60	2.50	3.20	1.25	2.50	2.50	*	*	1.60	3.20	3.20	*	*
F.14	1.00	1.60	2.00	2.50	*	1.60	2.50	3.20	*	*	2.00	3.20	*	*	*
F.15	1.25	2.00	2.50	3.20	*	2.00	3.20	*	*	*	2.50	*	*	*	*

("*" in the table denotes that a tube current setting is automatically switched and set at the most appropriate time.)

Table 7. Sensor sensitivity number and exposure time in digital mode (at 7mA with regular cone)

patient	Child					Adult					Obese				
teeth	T1	T2	T3	T4	T5	T1	T2	T3	T4	T5	T1	T2	T3	T4	T5
d.00	*	0.02	0.02	0.03	0.04	0.02	0.03	0.04	0.05	0.06	0.02	0.04	0.04	0.06	0.08
d.01	*	0.02	0.03	0.04	0.05	0.02	0.04	0.04	0.06	0.08	0.03	0.04	0.05	0.08	0.10
d.02	*	0.03	0.03	0.04	0.06	0.03	0.04	0.05	0.06	0.10	0.03	0.05	0.06	0.08	0.13
d.03	0.02	0.03	0.04	0.05	0.08	0.03	0.05	0.06	0.08	0.13	0.04	0.06	0.08	0.10	0.16
d.04	0.02	0.04	0.05	0.06	0.08	0.04	0.06	0.08	0.10	0.13	0.05	0.08	0.10	0.13	0.16
d.05	0.03	0.05	0.05	0.08	0.10	0.04	0.08	0.08	0.13	0.16	0.05	0.08	0.10	0.13	0.20
d.06	0.03	0.05	0.06	0.08	0.13	0.05	0.08	0.10	0.13	0.20	0.06	0.10	0.13	0.16	0.25
d.07	0.04	0.06	0.08	0.10	0.16	0.06	0.10	0.13	0.16	0.25	0.08	0.13	0.16	0.20	0.32
d.08	0.05	0.08	0.10	0.13	0.20	0.08	0.13	0.16	0.20	0.32	0.10	0.16	0.20	0.25	0.40
d.09	0.06	0.10	0.10	0.16	0.20	0.10	0.16	0.20	0.25	0.32	0.10	0.20	0.20	0.32	0.40
d.10	0.06	0.10	0.13	0.16	0.25	0.10	0.20	0.20	0.32	0.40	0.13	0.20	0.25	0.32	0.50
d.11	0.08	0.13	0.16	0.20	0.32	0.13	0.20	0.25	0.32	0.50	0.16	0.25	0.32	0.40	0.63
d.12	0.10	0.16	0.20	0.25	0.40	0.16	0.25	0.32	0.40	0.63	0.20	0.32	0.40	0.50	0.80
d.13	0.13	0.20	0.25	0.32	0.40	0.20	0.32	0.40	0.50	0.80	0.25	0.40	0.50	0.63	0.80
d.14	0.13	0.25	0.25	0.40	0.50	0.20	0.40	0.40	0.63	0.80	0.25	0.50	0.50	0.80	1.00
d.15	0.16	0.25	0.32	0.40	0.63	0.25	0.40	0.50	0.80	1.00	0.32	0.50	0.63	0.80	1.25

("*" in the table denotes that a tube current setting is automatically switched and set at the most appropriate time.)

Table 8. Sensor sensitivity number and exposure time in digital mode (at 4mA with regular cone)

patient	Child					Adult					Obese				
teeth	T1	T2	T3	T4	T5	T1	T2	T3	T4	T5	T1	T2	T3	T4	T5
d.00	0.02	0.03	0.04	0.05	0.08	0.03	0.05	0.06	0.08	0.13	0.04	0.06	0.08	0.10	0.16
d.01	0.02	0.04	0.05	0.06	0.10	0.04	0.06	0.08	0.10	0.16	0.05	0.08	0.10	0.13	0.20
d.02	0.03	0.05	0.06	0.08	0.10	0.05	0.08	0.10	0.13	0.16	0.06	0.10	0.10	0.16	0.20
d.03	0.03	0.06	0.06	0.08	0.13	0.05	0.08	0.10	0.13	0.20	0.06	0.10	0.13	0.16	0.25
d.04	0.04	0.06	0.08	0.10	0.16	0.06	0.10	0.13	0.16	0.25	0.08	0.13	0.16	0.20	0.32
d.05	0.05	0.08	0.10	0.13	0.20	0.08	0.13	0.16	0.20	0.32	0.10	0.16	0.20	0.25	0.40
d.06	0.06	0.10	0.10	0.16	0.20	0.10	0.16	0.20	0.25	0.40	0.10	0.20	0.25	0.32	0.40
d.07	0.06	0.10	0.13	0.20	0.25	0.10	0.20	0.20	0.32	0.40	0.13	0.25	0.25	0.40	0.50
d.08	0.08	0.13	0.16	0.20	0.32	0.13	0.20	0.25	0.32	0.50	0.16	0.25	0.32	0.40	0.63
d.09	0.10	0.16	0.20	0.25	0.40	0.16	0.25	0.32	0.40	0.63	0.20	0.32	0.40	0.50	0.80
d.10	0.13	0.20	0.25	0.32	0.50	0.20	0.32	0.40	0.50	0.80	0.25	0.40	0.50	0.63	1.00
d.11	0.13	0.25	0.25	0.40	0.50	0.25	0.40	0.50	0.63	0.80	0.25	0.50	0.63	0.80	1.00
d.12	0.16	0.25	0.32	0.50	0.63	0.25	0.50	0.50	0.80	1.00	0.32	0.50	0.63	1.00	1.25
d.13	0.20	0.32	0.40	0.50	0.80	0.32	0.50	0.63	0.80	1.25	0.40	0.63	0.80	1.00	1.60
d.14	0.25	0.40	0.50	0.63	1.00	0.40	0.63	0.80	1.00	1.60	0.50	0.80	1.00	1.25	2.00
d.15	0.32	0.50	0.63	0.80	1.25	0.50	0.80	1.00	1.25	2.00	0.63	1.00	1.25	1.60	2.50

(Unit : Sec.)

Table 9. Sensor sensitivity number and exposure time in digital mode (at 7mA with long cone)

patient teeth	Child					Adult					Obese				
	T1	T2	T3	T4	T5	T1	T2	T3	T4	T5	T1	T2	T3	T4	T5
d.00	0.02	0.04	0.05	0.06	0.10	0.04	0.06	0.08	0.10	0.16	0.05	0.08	0.10	0.13	0.20
d.01	0.03	0.05	0.06	0.08	0.10	0.05	0.08	0.10	0.13	0.16	0.06	0.10	0.10	0.16	0.20
d.02	0.03	0.06	0.06	0.10	0.13	0.06	0.10	0.10	0.16	0.20	0.06	0.10	0.13	0.20	0.25
d.03	0.04	0.06	0.08	0.10	0.16	0.06	0.10	0.13	0.16	0.25	0.08	0.13	0.16	0.20	0.32
d.04	0.05	0.08	0.10	0.13	0.20	0.08	0.13	0.16	0.20	0.32	0.10	0.16	0.20	0.25	0.40
d.05	0.06	0.10	0.10	0.16	0.20	0.10	0.16	0.20	0.25	0.40	0.10	0.20	0.25	0.32	0.40
d.06	0.06	0.13	0.13	0.20	0.25	0.10	0.20	0.25	0.32	0.40	0.13	0.25	0.25	0.40	0.50
d.07	0.08	0.13	0.16	0.20	0.32	0.13	0.25	0.25	0.40	0.50	0.16	0.25	0.32	0.40	0.63
d.08	0.10	0.16	0.20	0.25	0.40	0.16	0.25	0.32	0.40	0.63	0.20	0.32	0.40	0.50	0.80
d.09	0.13	0.20	0.25	0.32	0.50	0.20	0.32	0.40	0.50	0.80	0.25	0.40	0.50	0.63	1.00
d.10	0.13	0.25	0.32	0.40	0.50	0.25	0.40	0.50	0.63	1.00	0.32	0.50	0.63	0.80	1.00
d.11	0.16	0.25	0.32	0.50	0.63	0.25	0.50	0.50	0.80	1.00	0.32	0.63	0.63	1.00	1.25
d.12	0.20	0.32	0.40	0.50	0.80	0.32	0.50	0.63	0.80	1.25	0.40	0.63	0.80	1.00	1.60
d.13	0.25	0.40	0.50	0.63	1.00	0.40	0.63	0.80	1.00	1.60	0.50	0.80	1.00	1.25	2.00
d.14	0.32	0.50	0.63	0.80	1.25	0.50	0.80	1.00	1.25	2.00	0.63	1.00	1.25	1.60	2.50
d.15	0.32	0.63	0.63	1.00	1.25	0.63	1.00	1.25	1.60	2.00	0.63	1.25	1.25	2.00	2.50

(Unit : Sec.)

Table 10. Sensor sensitivity number and exposure time in digital mode (at 4mA with long cone)

patient teeth	Child					Adult					Obese				
	T1	T2	T3	T4	T5	T1	T2	T3	T4	T5	T1	T2	T3	T4	T5
d.00	0.04	0.06	0.08	0.10	0.16	0.06	0.10	0.13	0.16	0.25	0.08	0.13	0.16	0.20	0.32
d.01	0.05	0.08	0.10	0.13	0.20	0.08	0.13	0.16	0.20	0.32	0.10	0.16	0.20	0.25	0.40
d.02	0.06	0.10	0.13	0.16	0.25	0.10	0.16	0.20	0.25	0.40	0.13	0.20	0.25	0.32	0.50
d.03	0.08	0.13	0.13	0.20	0.25	0.10	0.20	0.25	0.32	0.40	0.13	0.25	0.25	0.40	0.50
d.04	0.08	0.13	0.16	0.25	0.32	0.13	0.25	0.25	0.40	0.50	0.16	0.25	0.32	0.50	0.63
d.05	0.10	0.16	0.20	0.25	0.40	0.16	0.25	0.32	0.40	0.63	0.20	0.32	0.40	0.50	0.80
d.06	0.13	0.20	0.25	0.32	0.50	0.20	0.32	0.40	0.50	0.80	0.25	0.40	0.50	0.63	1.00
d.07	0.16	0.25	0.32	0.40	0.63	0.25	0.40	0.50	0.63	1.00	0.32	0.50	0.63	0.80	1.25
d.08	0.16	0.32	0.32	0.50	0.63	0.32	0.50	0.63	0.80	1.00	0.32	0.63	0.63	1.00	1.25
d.09	0.20	0.32	0.40	0.50	0.80	0.32	0.63	0.63	1.00	1.25	0.40	0.63	0.80	1.00	1.60
d.10	0.25	0.40	0.50	0.63	1.00	0.40	0.63	0.80	1.00	1.60	0.50	0.80	1.00	1.25	2.00
d.11	0.32	0.50	0.63	0.80	1.25	0.50	0.80	1.00	1.25	2.00	0.63	1.00	1.25	1.60	2.50
d.12	0.40	0.63	0.80	1.00	1.25	0.63	1.00	1.25	1.60	2.50	0.80	1.25	1.60	2.00	2.50
d.13	0.40	0.80	0.80	1.25	1.60	0.63	1.25	1.25	2.00	2.50	0.80	1.60	1.60	2.50	3.20
d.14	0.50	0.80	1.00	1.25	2.00	0.80	1.25	1.60	2.00	3.20	1.00	1.60	2.00	2.50	*
d.15	0.63	1.00	1.25	1.60	2.50	1.00	1.60	2.00	2.50	*	1.25	2.00	2.50	3.20	*

("*" in the table denotes that a tube current setting is automatically switched and set at the most appropriate time.)

(2) ELECTRONIC CHIME ON/OFF

An electronic chime sounds when switches are depressed. If preferred, this sound can be deactivated as follows :

1. Keep T1 and T2 switches depressed together for more than 3 seconds.
Release the switches if the ready light starts to flash.
2. "bu. 2" will be displayed in exposure time display window.
3. By depressing either or switch, display changes to "bu.0".
4. Press **P switch** (Patient type Switch) to store this setting and turn off the main power switch.

NOTE : Exposure Warning Buzzer and alarm sound of error code can not be eliminated.

(3) PRIORITY OF SELECTIONS

Factory default setting :

Cone	: Regular cone
Film Speed	: "a"
Digital Imaging	: off
mA selection	: 7 mA
Patient Type	: Adult

If necessary, these settings can be changed. For example, if digital imaging is used for pedodontistry, digital imaging and "child" (patient type) shall be selected.

1. Keep 4mA selection switch and 7mA selection switch depressed simultaneously for more than 3 seconds. Release the switches if the ready light starts to flash
2. Press D switch momentarily. (Light above D switch illuminates and speed setting for digital imaging is displayed on exposure time display window.)
3. Select the patient type "child" by depressing P switch momentarily.
4. Press **T1 switch** to store these settings, then turn the main power switch off.
5. Cone type, mA selection can be changed by same procedures.

NOTE : For digital imaging, 4 mA is recommended to get good contrast and precise exposure time control.

SECTION 3 : DESCRIPTION FOR FUNCTIONS

[1] GENERAL

The Belmont Belray II 097 is advanced 70 kVp intra-oral x-ray machine consisting of four major components: tube head, balance arm, main controller and sub controller. Because of its modular design, sub controller can be readily remotely located to accommodate room design and radiation control requirements.

The main controller consists of power generator, timing and control circuits. Since Belray II 097 utilize the AVR (automatic voltage regulator) circuit instead of step up / down transformer to compensate line voltage fluctuation and also tube current is controlled by feed back system, quality of x-radiation is quit stable over whole range of exposure time from 1 pulse to 3.2 seconds. Precise and short exposure time enables Belray II 097 to use with the digital image receptor.

The tube head is a vacuum-sealed oil cooled unit with the high voltage transformer and x-ray tube self-contained. No high voltage lines run outside of the head. Except for mechanical repairs (yoke bearings, etc.) or external wiring problems, tube head must be replaced as a unit. It can not be opened in the field.

The counterbalanced arms provide a precisely balanced long reach support for the x-ray head. These arms contain highly tensioned springs which can cause serious injury if accidentally released.

⚠ CAUTION : DO NOT ATTEMPT TO DISASSEMBLE THESE ARMS IN THE FIELD.

[2] AUTOMATIC VOLTAGE REGULATOR

1. Belray II 097 is equipped with the automatic voltage regulator (AVR) in the control box. Purpose for this function is as follows.
 - a. As the line voltage fluctuation (including voltage drop during exposure) is absorbed, stabilized voltage is supplied to the high voltage transformer and filament transformer. As a result, output x-radiation is highly stabilized.
 - b. If auto transformer is used to compensate the voltage fluctuation, there always exists some voltage error because of stepping adjustment. AVR in Belray II 097 is using Field Effect Transistor to adjust the voltage, so no voltage error exists principally.
 - c. When line voltage fluctuates, in case of auto transformer operator must adjust the voltage by changing the tap of transformer. AVR circuit adjusts the voltage automatically and requires no operation to user.
 - d. The outer dimension and weight of control box can be reduced by eliminating a heavy auto transformer.
2. Block diagram of AVR circuit is described in FIGURE 3.
3. Power FET (field effect transistor) controls the AVR voltage as the voltage of reference sine wave and the voltage divided from AVR output becomes the same value and the same wave form.
4. Output voltage of AVR is 180 ± 1 Vac at 7 mA setting.

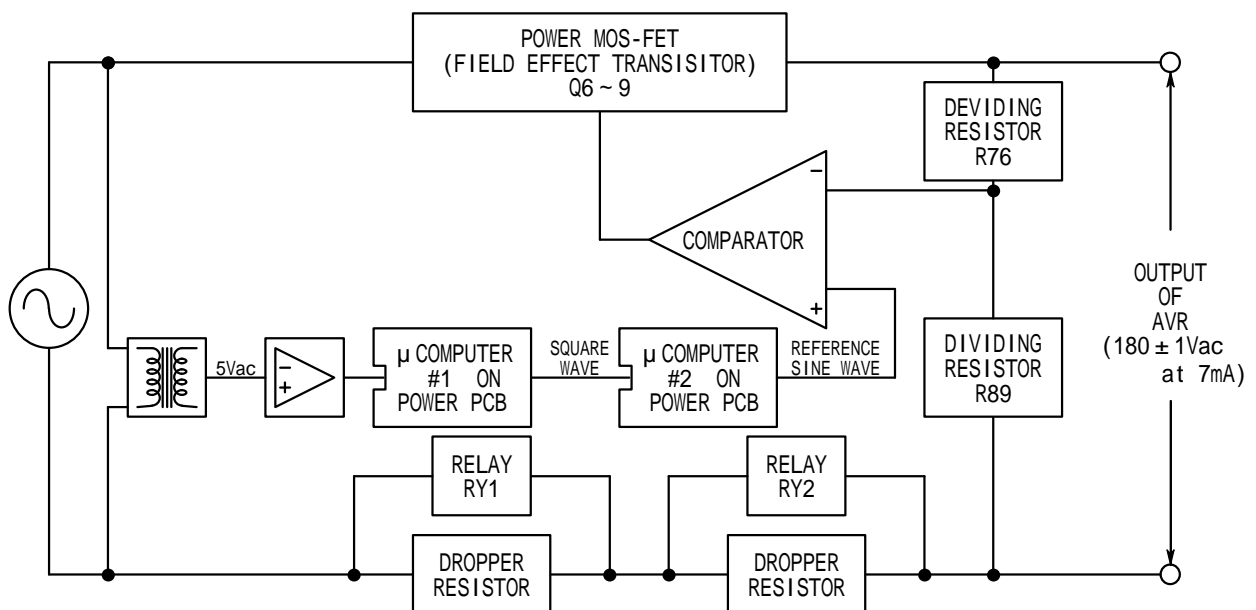

FIGURE 3. Block diagram of AVR circuit

[3] PRIMARY CIRCUIT OF HIGH VOLTAGE TRANSFORMER

1. Back reducer (parallel circuit of resistor and diode to reduce the reverse voltage of x-ray tube) and switching device (Triac) are added to AVR output and applied to the primary winding of high voltage transformer.
2. Both power lines to the primary winding of high voltage transformer are on and off by Triac and relay. Relay activates soon after the exposure switch is depressed and Triac turns on after the pre-heating period is finished and at zero crossing timing of line voltage.

[4] PRIMARY CIRCUIT OF FILAMENT TRANSFORMER

(1) CIRCUIT AND OPERATIONAL TIMING

1. Parallel circuit of resistor and transistor is added in series to the AVR circuit and applied to the primary circuit of filament transformer.
2. As Triac is not inserted in this circuit, voltage is applied to the filament transformer if the relay mentioned above turns on.
3. Triac in the primary circuit of high voltage transformer turns on at zero crossing point after the pre-heating period.

(2) ADJUSTMENT OF OUTPUT

1. The length of time period during the transistor makes the voltage across the resistor be shortened or opened decides the power to the filament of x-ray tube. To protect the filament, off period of the transistor is adjusted around the peak point of sine wave of line voltage.
2. Longer the off period of the transistor becomes, the primary voltage becomes lower and tube current decreases.
3. Although off period of the transistor during pre-heating is adjusted by h.xx value, off period during exposure cannot be adjusted manually as the micro computer adjusts it automatically for each pulse according to the tube current at that time. In this system, tube current during exposure can not be adjusted. To improve this, changing e.xx value makes the reference value for tube current increased or decreased.
4. After all, tube current at the beginning of exposure can be adjusted by h.xx setting and tube current at stabilized period of exposure is adjusted by e.xx setting. Both h.xx and e.xx have 32 stages, 00 ~ 1F (A=10, F=15). Higher setting makes tube current increased.

(3) OVER CURRENT PROTECTION

1. Over current protection in the AVR circuit works with relatively high current. As the rated current for primary circuit of filament transformer is approx. 0.2 Aac, this over current protection circuit will not work when the abnormal condition occurs in the filament circuit.
2. Current sensing resistor is inserted in the primary circuit of filament transformer. When the voltage across this resistor makes LED of photo coupler ON, "E.04" is displayed and output voltages to the high voltage transformer and filament transformer are terminated instantly.

[5] AUTOMATIC TUBE CURRENT CONTROL

(1) CIRCUIT

1. Tube current fed back from tube head is converted into voltage by the resistor (totally 500 Ω) on power generating PCB.
2. This voltage is integrated for each pulses of line frequency by the operational amplifier and applied to the micro computer.

(2) STABILIZING METHOD OF TUBE CURRENT

1. If the tube current of certain pulse measured by micro computer is lower than the rated value (4mA or 7mA), the off period of the transistor of next pulse is decreased. Shorter off period makes the output voltage for filament increased and as the result, tube current is increased.
2. If measured tube current is higher than the rated value, off period of next pulse is increased. Longer off period makes the output voltage for filament decreased and as the result, tube current is decreased.
3. This feed back control for filament is used during the exposure only. During pre-heating period, output for filament transformer is constant because no tube current is fed back.

SECTION 4 : ADJUSTMENT

[1] AVR VOLTAGE

Output voltage of Automatic Voltage Regulator circuit can be measured and adjusted as follows.
If AVR voltage has been adjusted, tube current must be adjusted after that.

1. Prepare a digital multimeter capable to measure 200 Vac with 1 % or more accuracy.
2. Turn off the main switch. Set the suitable range of digital multimeter to measure 200 Vac.
3. Open the front panel of the main controller and place one lead of multimeter to JP3-2 on the power PCB and other lead of multimeter to "TP2" a wire ring test terminal on the power PCB. (Refer to FIGURE 4A.)
4. Turn on the main switch on the main controller.
5. Depress the T2, T3 and P (patient) switches on the sub controller simultaneously until the letters "Adj" appears in the exposure time display window.
6. Select 7mA and press the exposure switch to get a reading. It should be 180Vac \pm 1Vac.

NOTE : TO PREVENT OVERHEATING OF THE FILAMENT, RELEASE THE EXPOSURE SWITCH AS SOON AS POSSIBLE AFTER THE VOLTAGE VALUE IS OBTAINED.

7. If the AVR voltage is higher than this range, adjust VR1, a pot at center of PCB, counterclockwise very slightly and repeat step 6 to get reading. Repeat until an AVR voltage setting becomes within the range of 180 \pm 1Vac.

⚠CAUTION : MAKE SURE 7 mA IS SELECTED. IF 4 mA IS SELECTED, VOLTAGE IN STEP #6 IS TOO HIGH AND HEAD WILL BE DAMAGED.

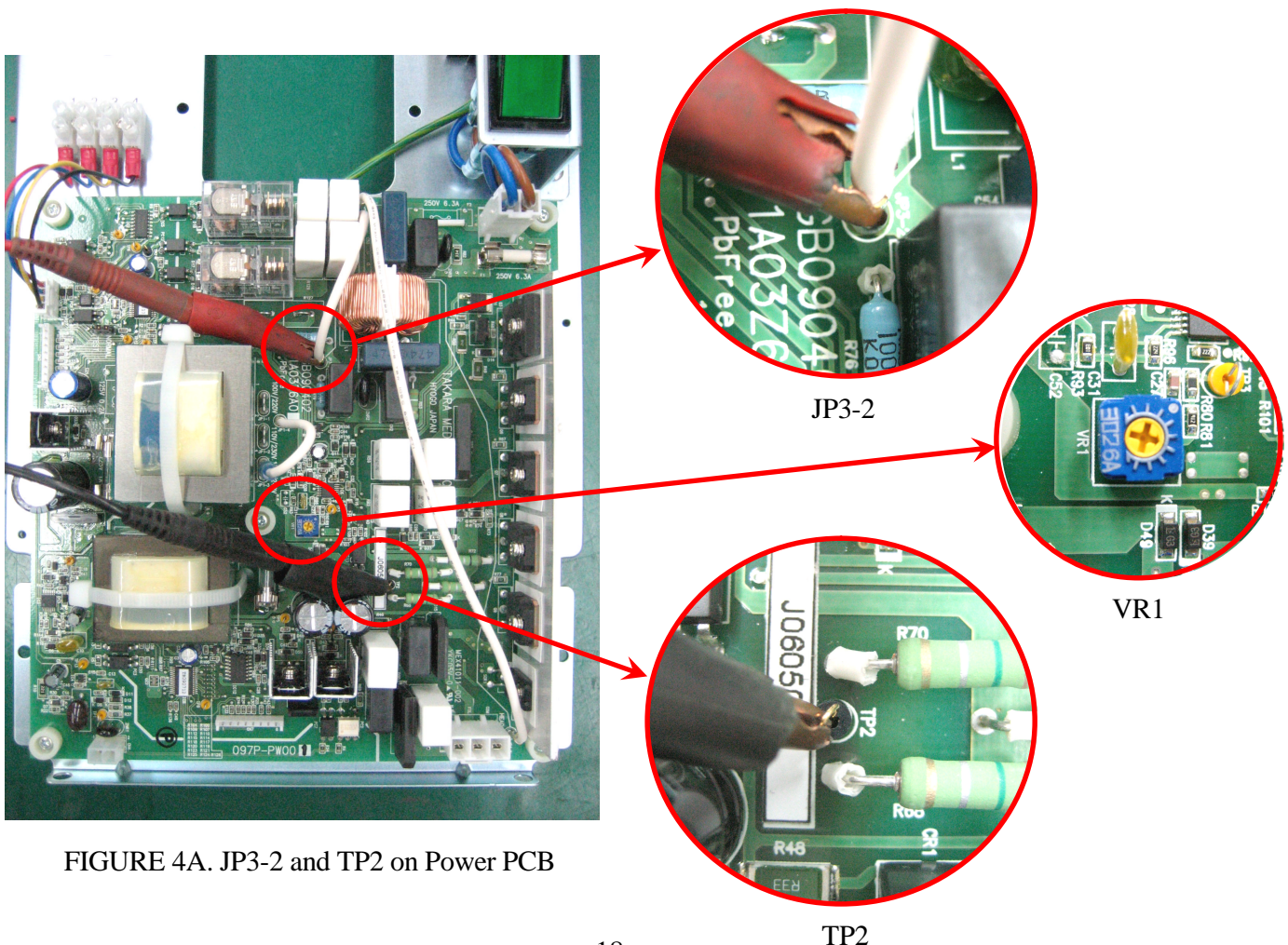

FIGURE 4A. JP3-2 and TP2 on Power PCB

Alternative method to adjust AVR voltage

Adjusting method of AVR voltage on page requires the tube head to be connected. If by any reason AVR voltage should be adjusted without head, following method can be used. In this method the reference voltage for AVR circuit is adjusted.

1. Prepare a digital multimeter capable to measure 10 Vac within ± 0.01 Vac accuracy.
2. Set the range of digital multimeter at 10Vac.
3. Turn off the main switch . Open the front panel of the main controller and connect one lead of multimeter to "TP3" a wire ring test terminal on the power generating PCB. Connect the other lead of multimeter to "TP2" test terminal on the power generating PCB. (Refer to FIGURE 4B.)
4. Turn on the main switch and select 7mA.

⚠CAUTION : MAKE SURE 7 mA IS SELECTED. IF 4 mA IS SELECTED, VOLTAGE IN STEP #5 IS TOO HIGH AND HEAD WILL BE DAMAGED.

5. Voltage reading should be within the range of 7.28 ~ 7.32 Vac at 7mA setting.
6. If the voltage is out of this range, then adjust VR1, a pot near the TP3 test terminal, very slightly to make the voltage reading within 7.28 ~ 7.32 Vac.

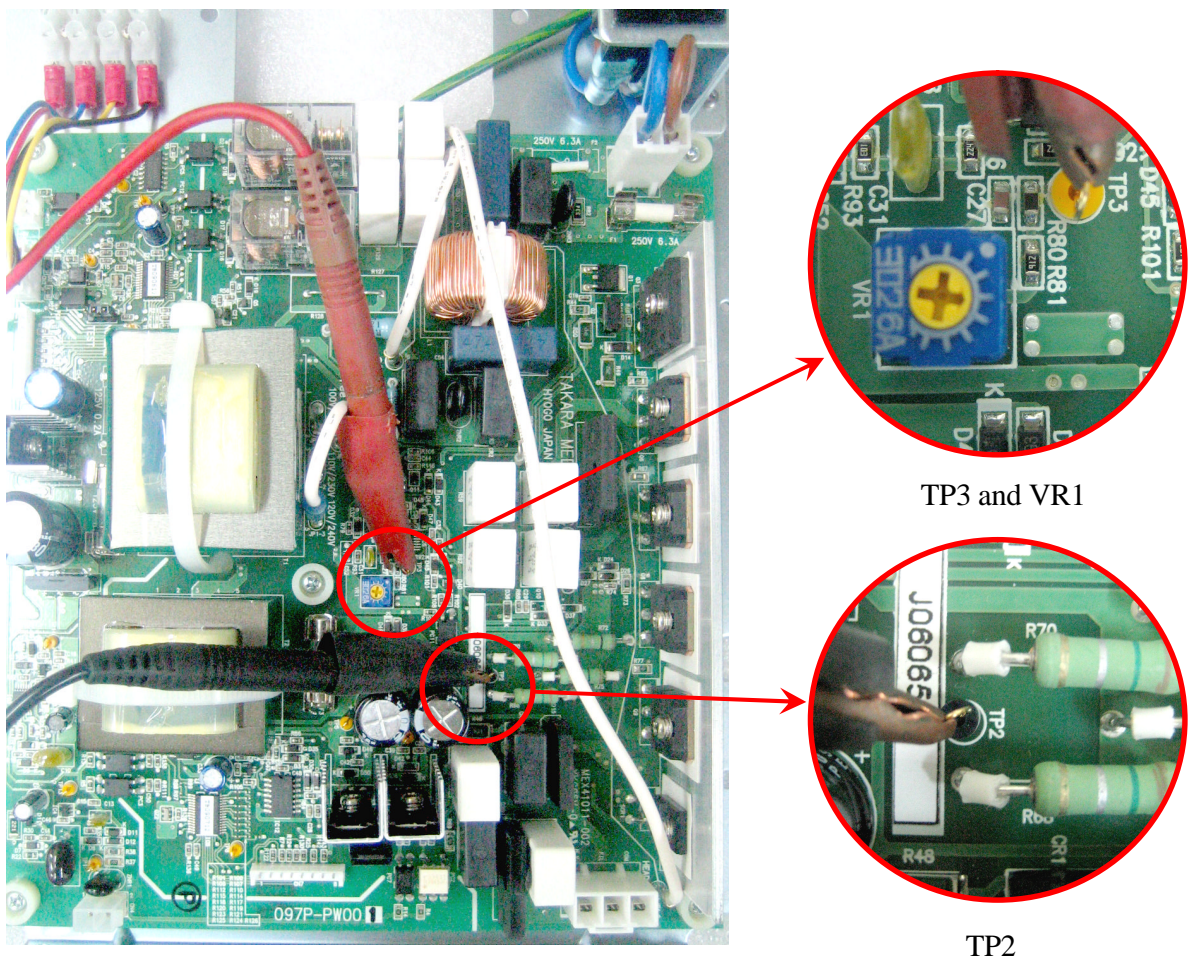

FIGURE 4B. TP2, TP3 and VR1 on the Power Generating PCB

[2] INSPECTION OF TUBE CURRENT

Belray II 097 has two types of self measuring function for tube current, i.e., auto mode and manual mode. Tube current can also be measured directly by multimeter.

In auto mode, both tube current at the beginning and stabilized period of exposure are checked and adjusted automatically, although the values of tube current are not displayed.

In manual mode, the value of tube current is displayed at the exposure time display window, but additional operations are necessary to adjust the tube current.

In case of two methods mentioned above, tube current is measured by the micro computer on the power generating PCB.

Last method is direct measurement of voltage. Tube current is converted into voltage by resistor R37 and R38 (totally 500 Ω) on power generating PCB. The voltage across these resistor becomes 3.5 Vdc, when tube current is 7 mAdc. In this method, the tube current only at stabilized period of exposure can be measured.

Auto mode is recommended for post installation confirmation and periodic maintenance.

a. Auto mode

1. Turn on the main power switch .
2. Depress the tooth selection switches T1, T4 and T5 together until 4mA light blinks.
3. Exposure time "0.50" is displayed and ready light is on. (If not, turn off main power switch and repeat step 2.) Then release T1, T4 and T5 switches.
4. Make an exposure by depressing the exposure switch.

⚠ WARNING : X-RADIATION IS GENERATED FOR 0.5 SECONDS.

5. If "h.XX" and "e.XX" are displayed alternately after the exposure, leave the unit for about 30 seconds until the display returns to "0.50". Then make another exposure again.
6. If "Fin" is displayed at the exposure time display window, tube current at the beginning of exposure and tube current at the stabilized period of exposure are within the specifications for both 4mA and 7mA.
7. Repeat step 5. until "Fin" is displayed.

b. Manual mode

Model 097 x-ray has the function displaying the tube current of the first pulse and the last pulse of the exposure at the exposure time display window. By this function, the tube current at the beginning and at the stabilized portion of the exposure can be measured.

1. Power on the control box.
2. Set the exposure time at 0.5 seconds by the manual adjusting switch next to the exposure time display window.
3. Make an exposure and keep the exposure switch depressed even after the exposure is over. Press the mA selection switch either 4 mA or 7 mA.
4. T1 tooth light comes on and tube current of the first pulse of the exposure is displayed at the exposure time display window, while the exposure switch is depressed.
5. Keep depressing the exposure switch, press the mA selection switch again. Then T5 tooth light comes on and tube current of the last pulse of the exposure is displayed at the exposure time display window. This value is tube current at the stabilized portion of the exposure.
6. If tube current of the first pulse is out of ± 2 mA from the rated current, perform the h.XX adjustment. If tube current of the last pulse is out of ± 1 mA from the rated current, perform the e.XX adjustment.

c. Direct measurement

1. Prepare a multimeter capable to measure 5 Vdc with 1% accuracy within 1 second.
2. Turn off the main switch.
3. Open the front panel of main controller.
4. Set to the suitable range of multimeter to measure 5Vdc.
5. Connect the positive lead of multimeter to test point TP1 at lower left corner on the power PCB and negative lead to the test point TP6 at upper left corner on the power PCB.
6. Turn on the main switch.
7. Set the exposure time to 2 seconds.
8. Make exposure and read the multimeter during exposure.

⚠WARNING: X-RADIATION IS GENERATED FOR 2 SECONDS.

9. Multiply the voltage reading by 2 becomes tube current. Ex. If reading is 3.45 Vdc, then tube current is $3.45 \times 2 = 6.9$ mA. This value is the tube current at the stabilized portion of the exposure. (By this method, tube current at the beginning of exposure cannot be measured.)

[3] ADJUSTMENT OF TUBE CURRENT

Tube current at beginning of exposure can be adjusted by h.xx setting and tube current at stabilized portion of exposure can be adjusted by e.xx setting.

If tube current is checked by auto mode as mentioned on page 20 and if tube current is out of range, successive exposure sets h.xx and e.xx to adequate value automatically.

If tube current is checked by manual mode as mentioned on page 20, h.xx and e.xx should be adjusted manually as follows.

(1) MANUAL SETTING METHOD FOR h.xx

1. Check tube current at beginning of exposure by manual mode as page 16. If tube current is out of the range of ± 0.5 mA from the rated current, perform following adjustment.
2. Turn on the main switch.
3. Keep depressing P (patient), C (cone), F (film) button until "h.xx" is displayed on the exposure time window.
4. Select the tube current that should be adjusted.
5. If tube current is lower than -0.5 mA at step 1, press switch next to the exposure time display window and h.xx value displayed will be increased. If tube current is higher than +0.5 mA, press switch and decrease the h.xx value displayed. xx has 32 kinds of values, 00 ~ 1F. Next to 9 is A and consequently F equals to 15.
6. Press the patient switch to memorize the h.xx value displayed to the memory. If value is stored, electronic chime will should twice.
7. Turn off the main switch and check the tube current at beginning of exposure again. If tube current is within ± 0.5 mA from the selected current, PH adjustment is finished. If tube current is still out of the range, repeat step 2 ~ 6 above.

(2) MANUAL SETTING METHOD FOR e.xx

1. Check tube current at stabilized portion of exposure by the manual mode (page 20) or by the direct measurement (page 21). If tube current is out of the range of ± 0.5 mA from the rated tube current, perform following adjustment.
2. Turn the main power switch.

3. Keep depressing P (patient), C (cone), F (film) button until "e.xx" is displayed on the exposure time window.
4. Select the tube current that should be adjusted.
5. Press T2 switch then display changes to "e.xx". xx is the value presently memorized.
6. If tube current is lower than -0.5 mA from the rated tube current at step 1, press switch next to the exposure time display window and e.xx value displayed will be increased. If tube current is higher than +0.5 mA, press switch and e.xx value displayed will be decreased. e.xx has 32 kinds of values.
7. Press the patient switch to memorize the e.xx value displayed to the memory. If value is stored, electronic chime will sound twice.
8. Turn off the main switch and check the tube current at stabilized portion of exposure again. If tube current is within ± 0.5 mA from the selected tube current, e.xx adjustment is finished. If tube current is still out of the range, repeat step 2 ~ 7 above.

[4] ADJUSTMENT OF LINE VOLTAGE MEASUREMENT ERROR

Line voltage is monitored by micro computer and if it is out of the operable range (90 ~ 100% of the rated voltage), the ready lamp on front panel becomes off and exposure is inhibited. The form of line voltage is a sine wave. Since the peak voltage of this sine wave is converted to measurable voltage and apply to micro computer, there exists a measurement error if the wave form is not perfect sine wave.

If measured RMS (Root Mean Square) voltage of power line by a precise multimeter is within the range of 90 ~ 100% of the rated line voltage, but the ready lamp on front panel doesn't come up, measured voltage by micro computer can be shifted ± 3 % as follows.

1. Turn on the main switch.
2. Keep depressing T2, T3 and T4 switches until "Pc.x" is displayed on the exposure time window.
3. Meaning of Pc value is as follows.
 - Pc.0 : No compensation is applied. initial setting from factory
 - Pc.1 : Measured voltage by micro computer is decreased by 3 %.
 - Pc.2 : Measured voltage by micro computer is increased by 3 %.
4. If multimeter indicates 107 ~ 110% of rated line voltage and ready lamp doesn't come on, set to "Pc.1" by depressing switch next to the exposure time display window.
5. If multimeter indicates 90 ~ 93% of the rated line voltage and ready lamp doesn't come on, set to "Pc.2" by depressing switch next to the exposure time display window.
6. After the display becomes suitable value, press the patient switch to store the value in the memory on timer PCB. If the setting is stored, electronic chime will sound twice.
7. Turn off the main switch and wait for a while and turn on again.
8. If the ready lamp is still off although the multimeter indicates 90 ~ 110% of the rated line voltage, the wave form of line voltage is far from sine wave more than 3% or transformer on the power generating PCB or timer PCB might be defective.

SECTION 5 : PERIODIC INSPECTION AND ADJUSTMENT

Following inspections and adjustments should be performed after installation, when parts are changed, and once every 6 months by a trained service technician to ensure that the x-ray unit is functioning with the manufacturer's specifications and remains in compliance with the standard.

[1] ELECTRICAL INSPECTION AND ADJUSTMENT

(1) POWER SUPPLY VOLTAGE

Power supply voltage must be within the operable range (90 ~ 110% of rated line voltage).

Confirm the power supply voltage before turning the unit on.

1. Open the front panel of control box by loosening two screws on top of control box.
2. Set the range of digital multimeter at 300Vac, connect probes of multimeter to L and N terminals of terminal block in the control box.
3. Confirm that the reading is rated line voltage $\pm 10\%$.

(2) CONFIRMATION OF TUBE CURRENT

Confirm the tube current at beginning and at stabilized portion of exposure by auto mode as page 16.

(3) EXPOSURE WARNING BUZZER AND LAMP

a. Exposure warning buzzer

Make an exposure and confirm that the exposure warning buzzer located within the control box is activated during the entire exposure.

b. Exposure warning lamp

Make an exposure and confirm that the exposure warning lamp illuminates during the exposure. Exposure warning lamp is located on the front panel of the control box.

(4) LINE VOLTAGE REGULATION

1. Make sure that a main power switch is "OFF".
2. Open the front panel of control box by loosening two screws on top of the control box.
3. Set the range of digital multimeter at 300Vac, connect probes of multimeter to L and N terminals of terminal block in the control box.
4. Turn the main power switch on, and select 7mA and set the exposure time at 2.00 seconds by switch next to the exposure time display window.
5. Record the no load line voltage (VN) indicated by the multimeter before the exposure.
6. Make an exposure and record the load voltage (VL) indicated by the multimeter during the exposure.

⚠ WARNING: X-RADIATION IS GENERATED FOR 2 SECONDS.

NOTE: Read the multimeter after the value is stabilized (about one second after the exposure starts.)

7. Calculate line voltage regulation R (%) in the formula below.

$$R = (VN - VL) / VL \times 100$$

R must not exceed the range of 0 ~ 2%. If it is greater than 2%, the size of the power supply wires must be increased. Refer to the power supply requirements of the model 097 installation instructions to determine the correct wire size necessary.

[2] MECHANICAL INSPECTION

(1) ARM ASSEMBLY

1. Incorrect leveling of the wall plate and wall bracket can cause arm drift. First, check leveling with horizontal arm in position #1. (FIGURE 5) If not correct, bracket must be adjusted by placing shims behind the wall plate.

IMPORTANT :

If the end of the horizontal arm shown in position #1 is pitched below level, then the tube head will drift away from the wall. If the end of the horizontal arm in position #1 is pitched above level, then the arm will require only minimum adjustment of the brake screw.

2. Check leveling in position #2. if not correct, adjust Horizontal Arm as follows : (FIGURE 5)
 - a. Slightly loosen two top mounting bolts for arm mounting bracket.
 - b. Shift the bracket left or right until the arms are accurately leveled.
 - c. Move the horizontal arm to position # 1.
 - d. Fully tighten two top mounting bolts.
 - e. Fully tighten bottom mounting bolt.

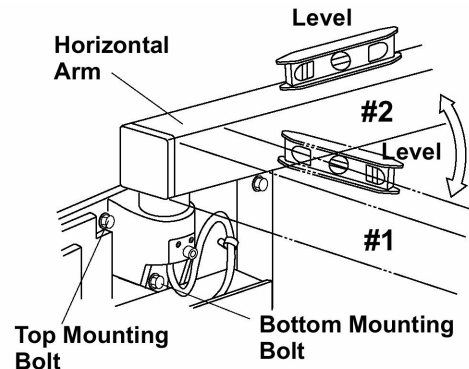

FIGURE 5.

NOTE : Slight tendencies to drift can be corrected by tightening brake screw in horizontal arm. Do not tighten beyond what is required to prevent drift.

(2) BALANCE ARM TENSION ADJUSTMENT

1. Place the balance arm assembly into position.
2. If either balance arm drifts higher or lower from the set position, remove the spring adjuster cover and adjust the balance arm spring tension with the balance arm wrench. (FIGURE 6)

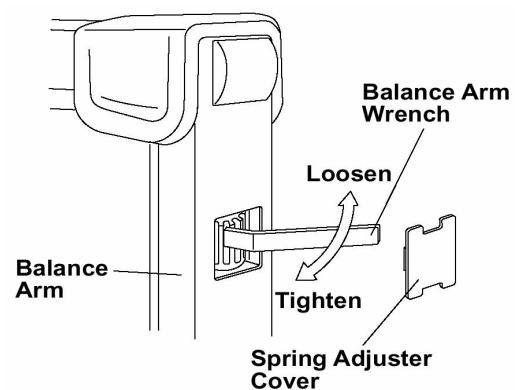

FIGURE 6.

(3) HEAD POSITIONING

- A. Place head into position.
- B. If head drifts from the set position, adjust the brake screws according to the following procedures.

(FIGURE 7)

1. Loosen the yoke side cap screw ($\varnothing 3 \times 8$ mm tapping screw) and remove the yoke side cap.
2. Adjust the six brake screws using a screw driver.
3. After adjustment, reattach the yoke side cap and screw.

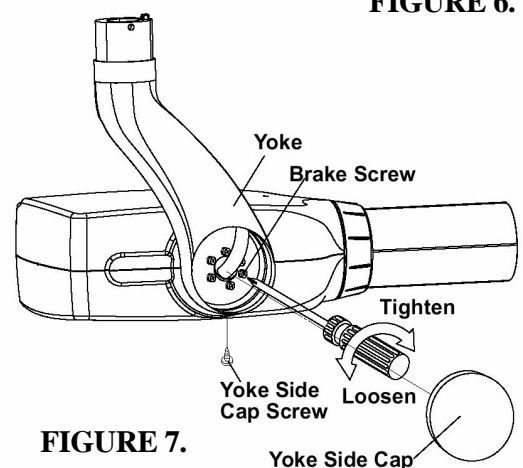

FIGURE 7.

(4) MECHANICAL SAFETY

1. The wall plate, if used, should be checked to confirm its secure attachment to the wall.
2. The arm mounting bracket should be checked to confirm its secure attachment to the wall mounting plate or, to the wall.
3. Check to insure the horizontal arm is not raising up and out of the arm mounting bracket. This should be observed routinely by treatment room personnel.

SECTION 6 : ERROR CODE

When abnormal condition exists in the unit, or malfunction occurs, error code is displayed in exposure time display window. Possible causes, check points and solutions for each error code are described below.

CODE	MEANING	POSSIBLE CAUSE	CHECK POINT	SOLUTION
E.00	Exposure switch is released before the exposure terminates.	a. Operator's fault.		Instruct operator to release the exposure switch after the exposure lamp turns off.
		b. Exposure switch or the coil cord for exposure switch is defective.	Disconnect the exposure switch from the sub-controller and check the continuity during the exposure switch is on.	If defect is found, exchange the exposure switch and cord.
E.01	Exposure switch is depressed within 10 sec. from the previous exposure.	Operator's fault.		Instruct operator to take a "wait" interval of 50 times of exposure time between two successive exposures.
E.02	Line voltage is less than 90 % of rated voltage.	a. Line voltage is less than 90% of the rated voltage.	Measure the incoming voltage between terminal L and N of terminal block in the control box.	If line voltage is less than 90% of the rated voltage, correct the voltage with additional step-up transformer.
		b. Wave form of line voltage is differ from sine wave.	Measure the incoming voltage between terminal L and N of terminal block in the control box.	If line voltage is close to 90% of rated voltage but over 90%, set PC.x setting to PC.2. (Press T2·T3·T4 and power switch for PC.x setting mode.)
E.03	Line voltage is more than 110% of rated voltage.	a. Line voltage is more than 110% of the rated voltage.	Measure the incoming voltage between terminal L and N of terminal block in the control box.	If line voltage is more than 110% of rated voltage, correct the voltage with additional step-down transformer.
		b. Wave form of line voltage is differ from sine wave.	Measure the incoming voltage between terminal L and N of terminal block in the control box.	If line voltage is close to 110% of the rated voltage but less than 110%, set PC.x to PC.1. (Press T2·T3·T4 and power switch for PC.x setting mode.)

CODE	MEANING	POSSIBLE CAUSE	CHECK POINT	SOLUTION
E.04	Excess line current during exposure.	a. Tube head is internally shorted.	Disconnect the tube head and make an exposure.	If E.07 comes, the tube head may be defective. Change the tube head.
		b. Cables between the control box and head are short circuited.	If E.04 still comes when the tube head is disconnected, disconnect the wires from the power PCB (CN4 and CN5) and make an exposure.	If E.07 comes, cables between the control box and head may be short circuited. Find the defective portion and correct it.
		c. Power PCB is defective.	Disconnect the wires from power PCB (CN4 and CN5) and make an exposure.	If E.04 still comes, power PCB may be defective. Change the power PCB.
E.05	Tube current of the last pulse is less than 3mA at 4mA setting or less than 5.25mA at 7mA setting.	AVR voltage is too low.	Measure the voltage between TP2 and JP3-2 on the power PCB when the exposure switch is pressed in the "Adj" mode. (Press P-T2-T3 for "Adj" mode.)	If the voltage is out of range of 180 ± 1 Vac, adjust the voltage to 94.5Vac by VR1 on the power PCB. After adjustment, tube current confirmation should be done.
			Measure the voltage between TP2 and TP3 on the power PCB at 7mA setting.	If the voltage is out of range of 7.30 ± 0.02 Vac, adjust the voltage to 7.30Vac by VR1 on the power PCB. After adjustment, tube current confirmation should be done.
E.06	Tube current of the last pulse is more than 5mA at 4mA setting or more than 8.75mA at 7mA setting.	AVR voltage is too high.	Refer to CHECK POINT of E.05	Refer to SOLUTION of E.05
E.07	Tube current during exposure is less than 2mA at 4mA setting or less than 3.5mA at 7mA setting.	a. AVR voltage is too low.	Refer to CHECK POINT of E.05	Refer to SOLUTION of E.05
		b. Cables between the control box and head are broken or mis-wired.	Check each cables for continuity and mis-wiring.	Correct the cable.
		c. Power PCB is defective.	If all cables are OK and AVR voltage cannot be adjusted to 180Vac or TP2 and TP3 voltage cannot be adjusted to 7.30 Vac at 7mA setting, power PCB may be defective.	Change the power PCB and check AVR voltage or TP2 - TP3 voltage again.
		d. Defect of tube head. (Filament damage.)	If AVR voltage and cable are all right, tube head may be defective.	Change the tube head and confirm the function again.

CODE	MEANING	POSSIBLE CAUSE	CHECK POINT	SOLUTION
E.08	Tube current during exposure is more than 6mA at 4mA setting or more than 10.5mA at 7mA setting.	a. AVR voltage is too high.	Refer to CHECK POINT of E.05	Refer to SOLUTION of E.05
		b. Cables between the control box and head are broken or mis-wired.	Check each cables for continuity and Mis-wiring.	Correct the cable.
		c. Power PCB is defective.	If all cables are OK and AVR voltage cannot be adjusted to 180Vac or TP2 and TP3 voltage cannot be adjusted to 7.30 Vac, power PCB may be defective.	Change the main PCB and check AVR voltage or TP2 - TP3 voltage again.
		d. Defect of tube head. (Internal short)	If AVR voltage and cable are all right, then tube head may be defective.	Change the tube head and confirm the function again.
E.09	Malfunction of the micro-computer.	Memory setting for lower limit of line voltage is higher than the higher limit of line voltage.	Check the L.xx value and H.xx values in the line voltage limit setting mode. (Press T1·T3·T5 and power switch for this mode.)	If L.xx is higher than H.xxx, adjust these settings. (Refer to the solutions for possible cause "c" of E.02 and E.03. If these values cannot be adjusted, display PCB may be defective.
E.10	Exposure switch or exposure switch circuit is ON, when main power switch is turned ON.	Exposure switch or the coil cord for exposure switch is defective.	Turn off the main switch and disconnect form the timer PCB. Turn on the main switch again.	If E.10 does not appear, change the exposure switch or coil cord for exposure switch.
				If E.10 still appears, change the timer PCB.
E.11	Tube current is detected during pre-heating period.	High voltage is applied to x-ray tube during pre-heating period.	Turn off the main switch and wait for a while. Turn on the main switch again.	If E.11 still appears, change the power PCB.
E.12	Tube current is detected, when main power switch is turned ON.	Both relay and triac are broken or MA feedback circuit is defective.	Turn off the main switch and wait for a while. Turn on the main switch again.	If E.12 still appears, change the power PCB.
E.22	Failure of communication between power PCB and time PCB.	Electrical noise makes mis-communication.	Turn off the main switch and wait for Approximately 2 min. Turn on again.	If E.22 still appears, check the cable between the PCBs.
E.23	Any switch on the sub-controller is depressed when the power switch is turned on.	Some switch on the timer PCB is defective.	Turn off the main switch and wait for Approximately 2 min. Turn on again.	If E.23 still appears, change the Timer PCB.

SECTION 7 : TROUBLE SHOOTING

Error code is displayed in the exposure time display window for most troubles in daily usage. So the error code table in section 6 can be used as trouble shooting chart in most case. Some troubles that don't make error code displayed are listed in the following table with their possible causes, check points and solutions.

PROBLEM	POSSIBLE CAUSE	CHECK POINT	SOLUTION
1. "FIN" doesn't appear in the tube current confirmation mode. (P.19 of installation manual)	AVR voltage is too high or too low.	Measure the voltage between TP2 and JP3-2 on power PCB, when the exposure switch is pressed in the "Adj" mode. (Press P-T2-T3 for "Adj" mode.)	If the voltage is out of range of $180 \pm 1\text{Vac}$, adjust the voltage by VR1. After adjustment, tube current confirmation should be done.
			If the voltage is within the range, set final h.xx and e.xx values manually. (Press P-C-F and power switch for manual setting mode.)
2. AVR voltage cannot be adjusted to 94.5 Vac in the "Adj" mode.	a. Cables between the control box and head are broken or mis-wired.	If AVR voltage is staying around line voltage, cables may be broken. (especially #3 and #5 cables)	Correct the cable.
	b. Power generating PCB or timer PCB is defective.	If cables are OK, either PCB may be defective.	Change the power PCB first and if AVR voltage still cannot be adjusted, change timer PCB.
3. Exposure does not start when exposure switch is depressed.	a. Exposure switch is defective.	Disconnect CN2 from timer PCB and short the terminal #1 and #3 of CN2 instead of pressing the exposure switch. If exposure can be made, exposures switch is defective.	Change the exposure switch.
	b. Exposure time setting is "0.00".	Check the exposure time display window.	Press a tooth switch or manual setting switch for exposure time.
4. Radiograph is too dark or too light.	a. Exposure time is too long or too short.	Check the tooth, patient, cone and film type are adequate.	Proper tooth, patient and cone type should be selected. If film type is different, set adequate film speed.
	b. Processing condition is not adequate.	Check the solution, temperature or processing speed, etc.	Correct the processing condition.
	c. Tube current is too high or too low.	Check the tube current. (Refer to page 16 of this manual.)	If tube current is out of $\pm 0.5\text{mA}$, adjust h.xx and e.xx value.

SECTION 8 : REPLACEMENT OF COMPONENT

[1] CONTROL BOX

(1) POWER GENERATING PCB

1. If one or more results of verification checks are out of specification or trouble shooting chart indicates, power generating PCB should be replaced.
2. Since power MOS FETs and C-MOS micro computer chips are used, great care should be paid against electrostatic discharge (ESD).
 - a. Personnel who handle PCB should touch the grounding screw (green/yellow wire) in the control box and discharge the static electricity from his body before working.
 - b. Replaced PCB should be stored in the anti-static bag.

(2) TIMER PCB

1. If one or more results of verification checks are out of specification or trouble shooting chart indicates, timer PCB should be replaced.
2. Since micro computer on the timer PCB is C-MOS type, same care as power generating PCB should be paid against ESD.
3. Since screws are used against plastic panel, don't over tighten when installing a new PCB.
4. After new timer PCB is installed, following confirmation, adjustment and setting must be performed. If the setting of b.-d. below is not changed from factory setting for the previous timer PCB, only a. is necessary. (a is always necessary.)
 - a. Tube current confirmation and adjustment.
 - b. Film speed setting.
 - c. Priority setting for patient, cone and film speed.
 - d. Electronic chime on/off setting

[2] TUBE HEAD

1. If one or more results of verification checks are out of specification or trouble shooting chart indicates, tube head should be replaced.
2. When dismantling the head from arm, be careful of the arm.

⚠WARNING : AS BALANCE ARM IS HIGHLY TENSIONED, IT IS NECESSARY TO PLACE THE HEAD AT MAXIMUM HEIGHT BEFORE REMOVING HEAD.

3. After new head is mounted, adjustment of tube current is always necessary. Perform h.xx and e.xx adjustment according to the steps described at auto mode on page 19.

SECTION 9 : CIRCUIT DIAGRAM

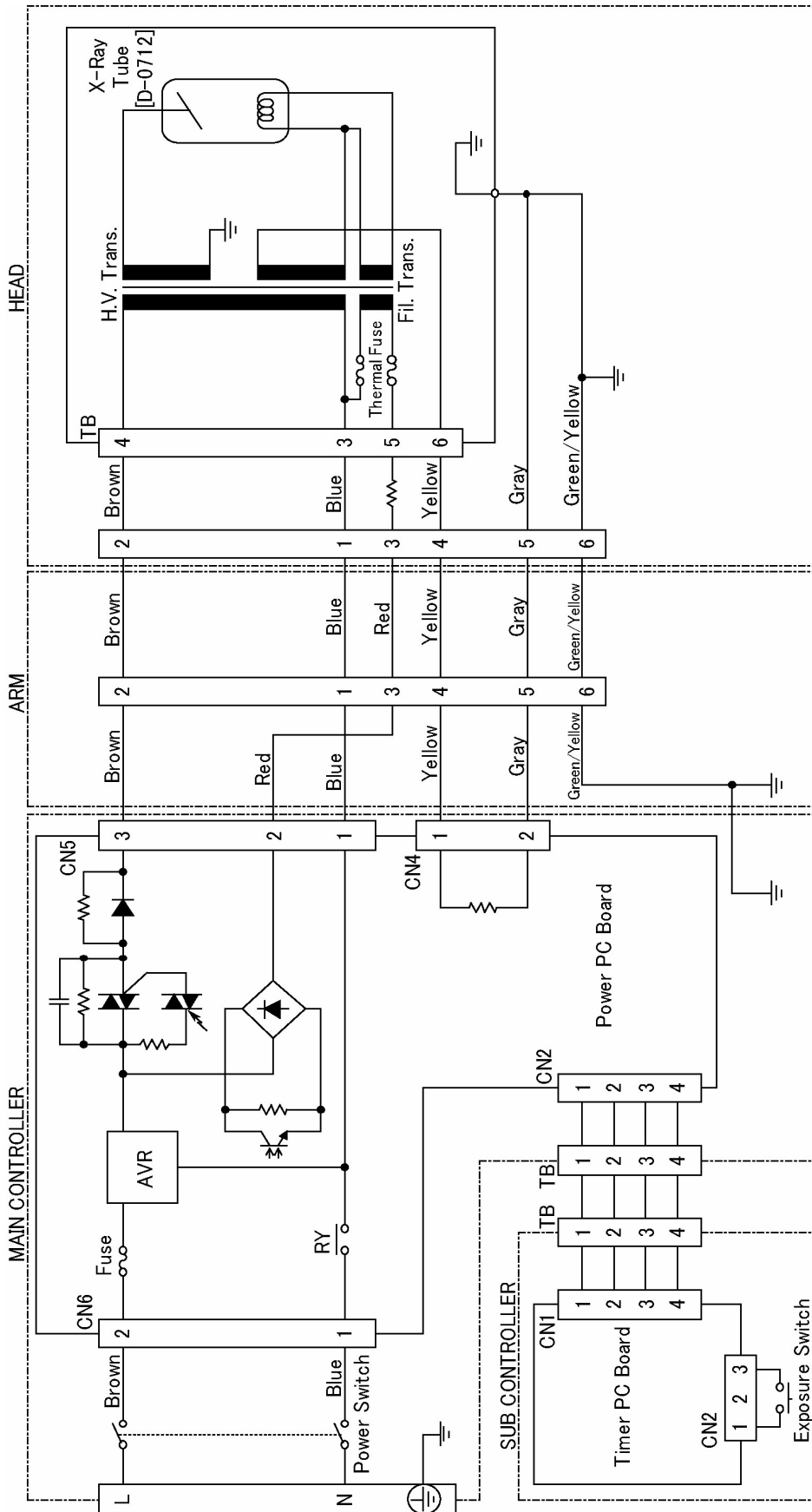

NOTE

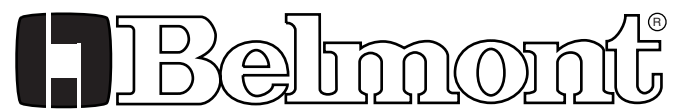

TAKARA BELMONT CORPORATION

2-1-1, Higashishinsaibashi, Chuo-ku, Osaka, 542-0083, Japan

TEL. : (06)6213-5945 FAX. : (06)6212-3680

Book No.1A091AA0

Printed in Japan 2011-10 TM