

DENTAL LIGHT

300LED DENTAL LIGHT

TYPE

- 301 POLE MOUNT
- 302 CEILING MOUNT
- 305 TRACK MOUNT
- 320S UNIT MOUNT

OPERATING INSTRUCTIONS

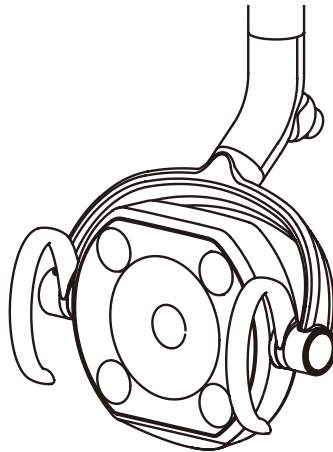

IMPORTANT

Thank you for purchasing TAKARA BELMONT product.

- This manual provides operating instructions for the 300LED DENTAL LIGHT.
- The instructions contained in this booklet should be thoroughly read and understood before operating the 300LED DENTAL LIGHT.
- After the installation has been completed, keep this manual in a safe place and refer to it for future maintenance.
- If you have any questions about this Manual or this product, please contact us. If manual becomes unreadable or is lost, please request a new manual by contacting your dealer.
- Installation should be conducted by authorized personnel only. Follow instructions on installation manual.



TABLE OF CONTENTS

Intended Use of the Product	
Important Notes	
Symbols	
Safety Precautions	1~3
Overview and Major Components	3~5
Descriptions of Operation and Functions of Components	
■ Main Switch	6
■ Functional Description	6
■ Operation	7
Care and Maintenance	
■ Cleaning	8
■ Disinfection of product exterior	8
Storage, Lifetime, Consumable, Stock Period of Parts and Disposal	8
Before Asking for Repairs	9
Specifications	10~14
Maintenance and Inspection	15~16

Intended Use of the Product

This product is an active therapeutic device intended for the exclusive use for diagnoses, treatments and relative procedures of dentistry. The product must be operated or handled by the qualified dentists or by dental staffs under the supervision of the dentist.

Such dentists or dental staffs should instruct and/or assist the patients to approach to and leave from the product. Patients should not be allowed to operate or handle the product unless he/she is so instructed.

Important Notes

In case of the troubles, please contact Takara Belmont offices or your dealers.













Do not disassemble or attempt to repair.

Disassembly, repair or modifications should only be done by a qualified repair technician.

Attempts at disassembly, repair or modifications may lead to abnormal operation and accidents.



Symbols

Following symbols are used on the switch, labels and in this manual of 300LED DENTAL LIGHT. Confirm the meaning of each symbol.











	ON (power)	○	OFF (power)	⏏	Functional earth	⏏	Protective earth (ground)
	Caution It means "caution, warnings, or possibility to danger".		Flammable warning symbol		Electrical shock symbol		General prohibited behaviors
	Prohibition of disassembly, repair or modification		Indicates enforcement or Instruction for general user behavior		Instruction to ground the product appropriately		Alternating current
— — —	Direct-current		Showing the company name and its address of manufacturer		Showing the date of manufacture		Refer to instruction manual/booklet
	Showing the LED radiation						

Safety Precautions

- Before use, read the “Safety precautions” carefully to ensure proper use.
- The following information is designed to ensure safe use of this product and to prevent injury and damage to you and others. The precautions contained here are classified depending on the severity and degree of imminence of possible injury or damage resulting from improper use. Be sure to follow all the information, which is important for safety.





Classification of precautions	Severity and degree of imminence of possible injury or damage
 WARNING	This symbol indicates that “ignorance of these precautions may lead to severe injury or even death as a result of improper use.”
 CAUTION	This symbol indicates that “ignorance of these precautions may lead to mild or moderate physical injury or damage to property as a result of improper use.”
NOTICE	This symbol indicates that “it is recommended to follow these precautions for safety.”

WARNING









	1. Be sure to turn off breakers for equipment in the clinic when this product will not be used for a long period of time
	Be sure to turn off breakers for equipment in the clinic when this product will not be used for a long period of time (following the completion of work, during the suspension of business, etc.). Insulation degradation may cause electrical fire.
	2. Be sure to turn off the main switch upon completion of work or during work breaks
	Be sure to turn off the main switch upon completion of work or during work breaks. This prevents incorrect operation due to accidental contact and associated hazards.
	3. Never disassemble, repair or modify this product
	Individuals other than certified repair technicians should not disassemble or attempt to repair and modify this product. This could lead to an accident, failure, electric shock or fire.
	4. Be sure to establish a grounding connection
	Be sure to establish a proper grounding connection. (Refer to a vendor for grounding connection.) Failure or electric leakage may lead to electric shock.
	5. Use with caution on patients with a cardiac pacemaker
	Use this product with extreme caution on patients with a cardiac pacemaker. In the case of any abnormalities in patients during use, immediately turn off this product and discontinue use.
	6. Do not direct the LED light source toward the eyes
	The LED is very bright. Do not direct the LED beam into the patient's or user's eyes. Doing so may cause trouble on them.
	7. Ensure the maintenance of this product
	Failure to maintain this product may lead to physical injury or property damage.
	8. Protecting patient and user
	Follow this instruction manual to ensure proper use.

Safety Precautions

WARNING

	<p>9. Always keep your eyes on a patient</p> <p>Keep a patient away from touching equipment or control switches</p>
	<p>10. Use with caution in the presence of electromagnetic interference waves</p> <p>Do not place this product around equipment generating electromagnetic waves (including communications equipment, elevators, etc.) as incorrect operation of this product may occur in the presence of electromagnetic interference waves. Do not use equipment generating electromagnetic waves, such as mobile phones, around this product.</p>
	<p>11. Do not place an over load on the arm. Avoid rough handling</p> <p>Move the light arm smoothly. Do not lean an elbow or hang on to the light arm. This could cause damage to this light arm.</p>
	<p>12. Do not operate equipment with the device that emits electromagnetic wave</p> <p>Do not use electric surgical knife or laser knife with dental light. Light may turn on/off by itself due to malfunction of a sensor caused by electromagnetic interferences.</p>

CAUTION

	<p>1. Only experienced personnel should use this product</p> <p>Only dentists or other dental professionals should use this product.</p>
	<p>2. Do not smack or rub this product</p> <p>Do not smack or rub this product forcefully. This could cause damage to covers or defective function.</p>
	<p>3. Do not give an impact on equipment</p> <p>Impact may damage LED or arm section. Continuous impact may drastically shorten LED life.</p>
	<p>4. Do not grease</p> <p>Do not apply grease (when you hear noise from arm section). Newly applied grease may cause chemical reaction with factory applied grease. This may cause oil (grease) leak.</p>
 	<p>5. Precautions for cleaning</p> <p>Do not use volatile chemical (Alcohols except ethanol for disinfection, thinner, gasoline, kerosene), abrasive wax, abrasive sponge etc. Some ethanol for disinfection may damage the surface. Always wipe off ethanol. Cleaning the resin cover with a wet soft cloth or use a mild detergent diluted to an approximately 10% solution. Gently wipe a lens cover with a soft cloth.</p>
	<p>6. Discontinue use if you feel that “something is wrong”</p> <p>Always be careful to inspect this product for looseness, rattling, tilting, wobbling, sounds, temperature, odors, etc. Immediately discontinue use at the first feeling that “something is wrong.”</p>
	<p>7. Be sure to operate switches with your hands</p> <p>Be sure to operate switches with your hands. Operation with body parts other than hands may cause damage or incorrect operation.</p>
	<p>8. Immediately wipe off drug solution when it comes into contact with this light</p> <p>Should drug solution or water come into contact with this light, immediately wipe it off with a dry soft towel, etc. This could result in defective function or electric leakage as well as spotting or rusting.</p>

Safety Precautions

⚠ CAUTION



9. Cleaning of grease leak

If grease leaks from arm section, please wipe grease off.



10. Irradiation light of LED

Use of controls or adjustments or performance of procedures other than those specified herein may result in hazardous radiation exposure.

NOTICE

1. Troubleshooting and contact information

In the case of any problems, discontinue use, turn off the main switch and contact the dealer or our company.

Overview and Major Components

Overview and Major Components

TYPE 301

Light Head (Rear side)

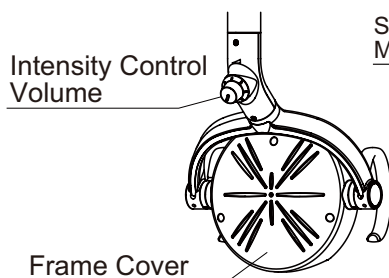

Power Supply Box

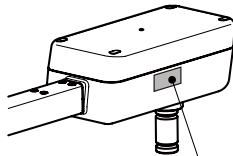

Label ①
Caution Label

“CAUTION—Electric Shock hazard, do not remove cover. Refer servicing to qualified service personnel”.

Label ②
LED Caution Label

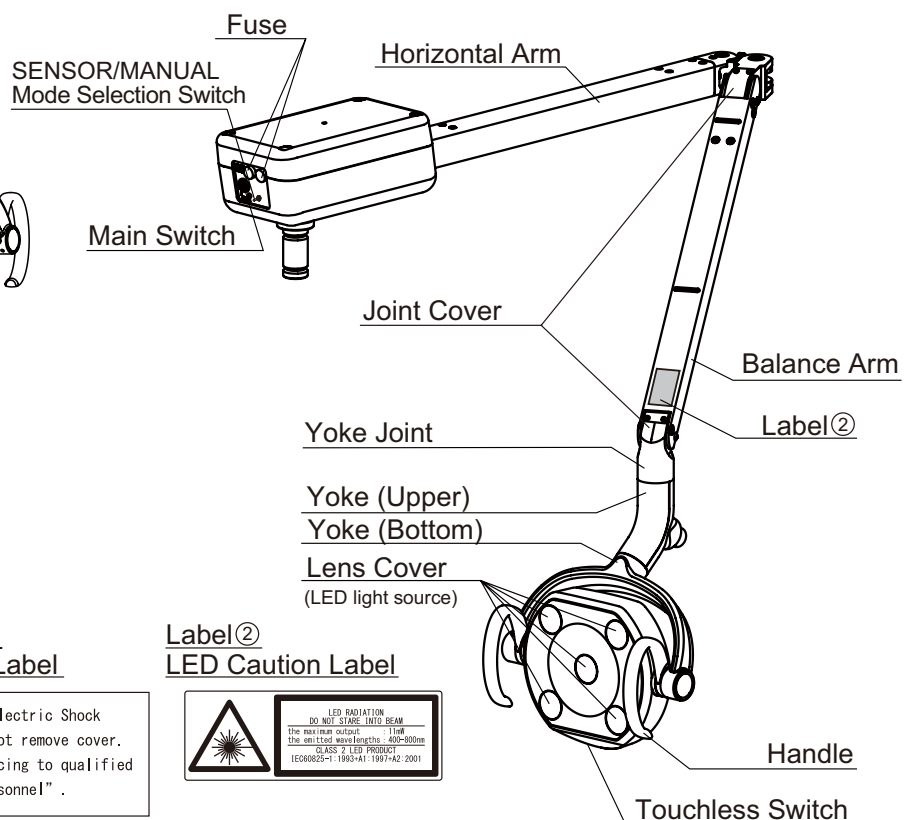

Accessories

Adjustment Bar x 1, Operating Manual x 1, Installation Manual x 1

* keep adjustment bar and manuals for future maintenance.

Installation manual describes use of the adjustment bar.

Overview and Major Components

Overview and Major Components

TYPE 302

Light Head Section (Rear side)

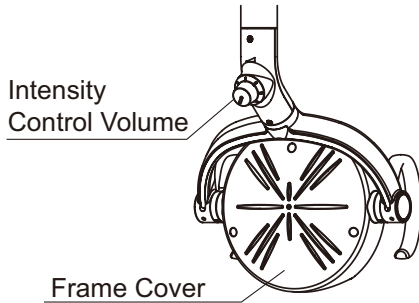

Power Supply Box Section

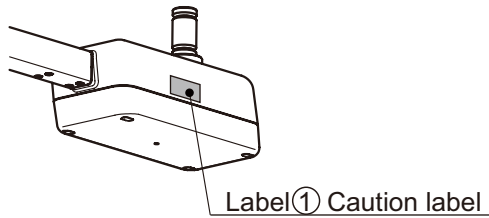

※ See page 3 for details of label ①,②

Accessories

Adjustment Bar x 1, Operating Manual x 1, Installation Manual x 1
 * keep adjustment bar and manuals for future maintenance

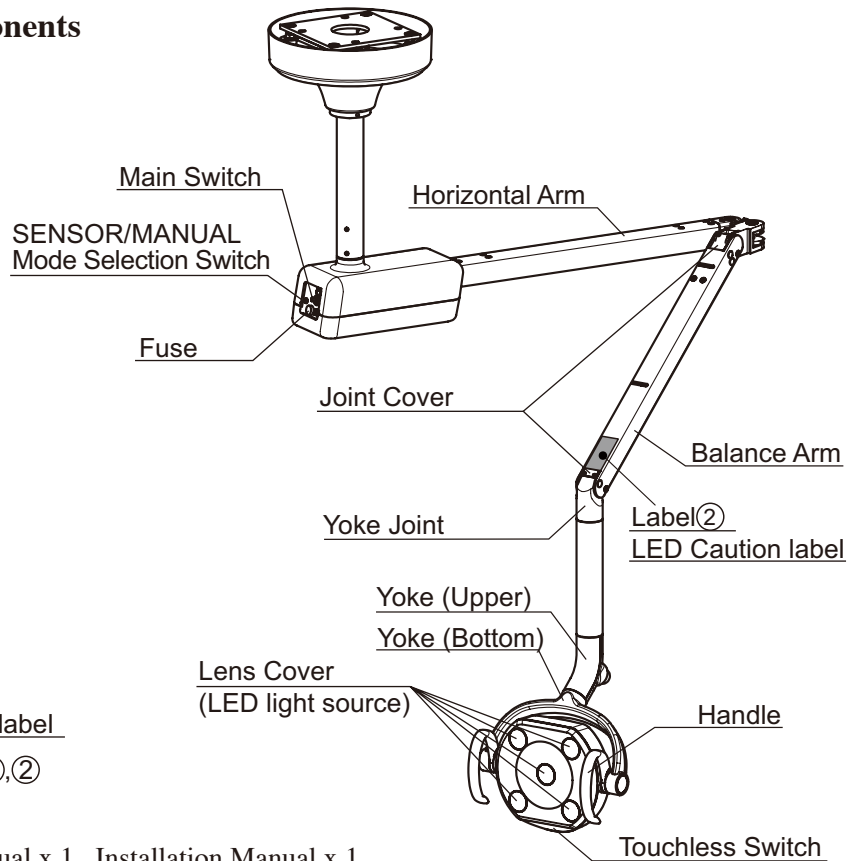

Overview and Major Components

TYPE 305

Light Head Section (Rear side)

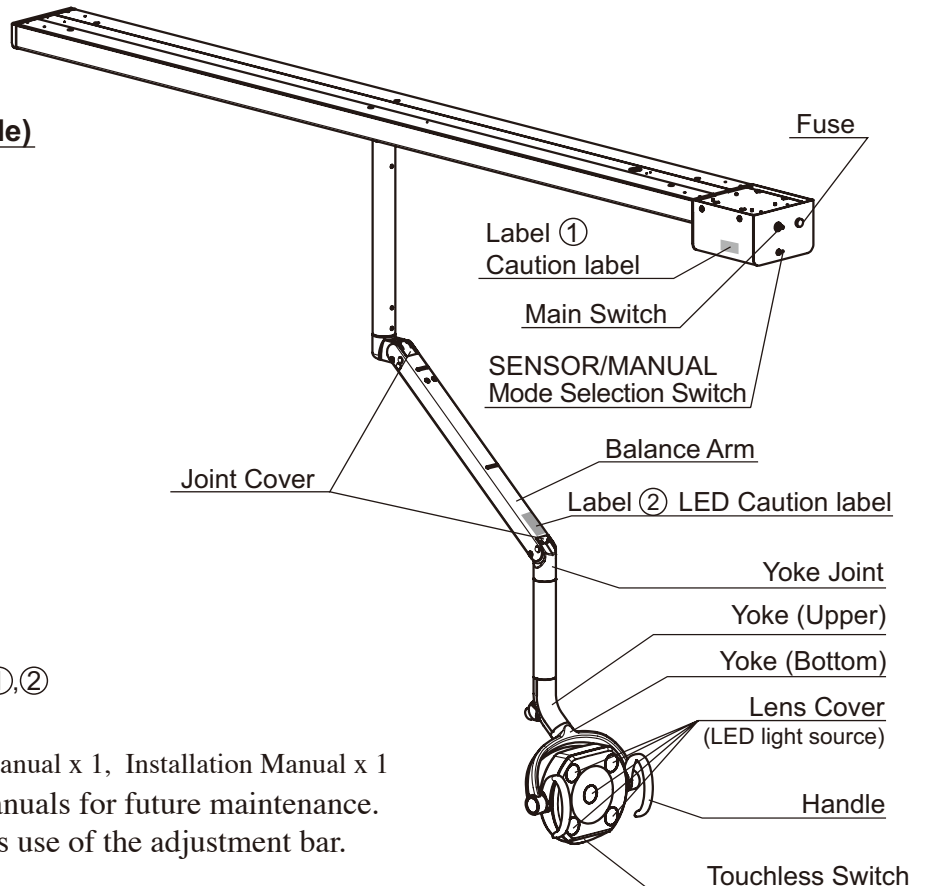
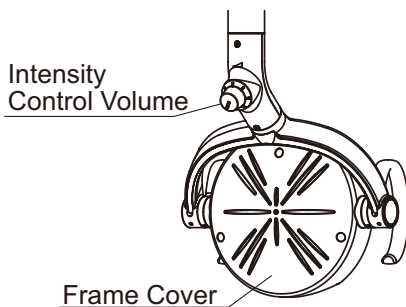

※ See page 3 for details of label ①,②

Accessories

Adjustment Bar x 1, Operating Manual x 1, Installation Manual x 1
 * keep adjustment bar and manuals for future maintenance.
 Installation manual describes use of the adjustment bar.

Overview and Major Components

■ Overview and Major Components

TYPE 320S

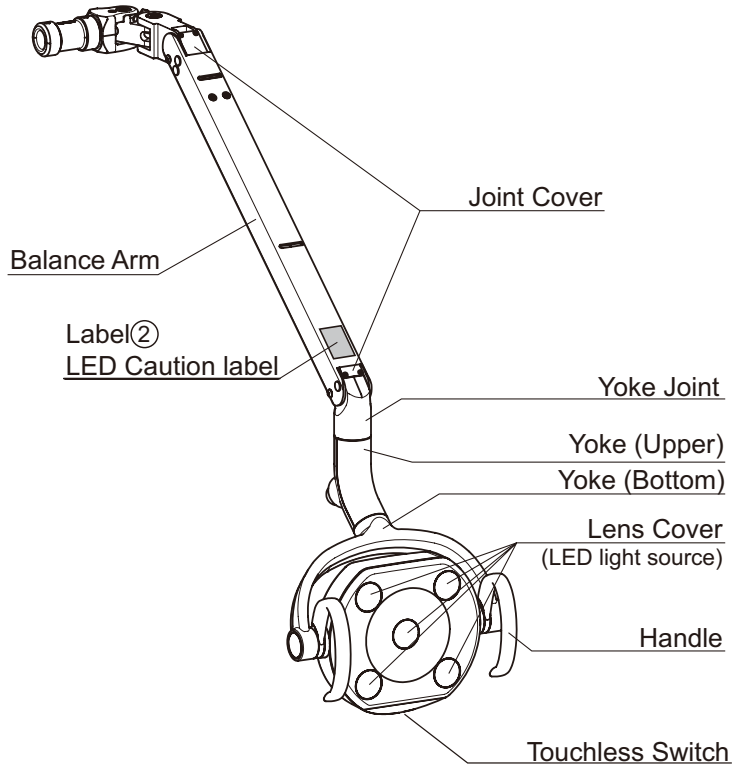

Light Head Section (Rear side)

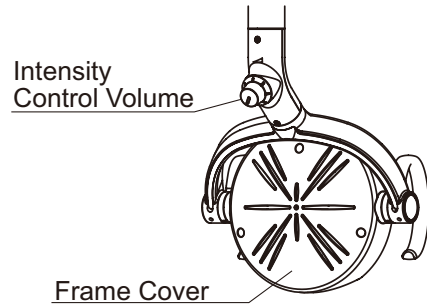

※ See page 3 for details of label ②

■ Accessories

Adjustment Bar x 1, Operating Manual x 1, Installation Manual x 1

* keep adjustment bar and manuals for future maintenance.

Installation manual describes use of the adjustment bar.

Description of Operation and Functions of Components

■ Main Switch

- TYPE 301, 302, 305

Turn on the main switch to the side marked with [I] and switch to the side marked with [O] for turn off.
Position of the main switch, see page 3 ~ 4 for [Overview and Major Components] section.

- TYPE 320S

Turn on the main switch of the unit side to the side marked with [I] and switch to the side marked with [O] for turn off.

⚠ WARNING

- Be sure to turn off the main switch upon completion of work or during breaks. This prevents incorrect operation due to accidental and associated hazards.
- Be sure to turn off breakers for equipment in the clinic when this product will not be used for a long period of time (following the completion of work, during the suspension of business, etc.). Insulation degradation may cause electrical fire.

■ Functional Description

- 300LED dental light has two operation modes (normal treatment mode and composite mode).

Normal treatment mode: Brightness can be adjusted steplessly between 3,100 ~ 28,000lux

Composite mode: Brightness is kept at 4,300lux

- 300LED dental light is equipped with a touchless sensor switch. Turning on/off and transition to composite mode can be done with a touchless sensor switch. Place your hand in front of a touchless sensor.

Effective sensing area is 65mm depth, 15mm width.

- 300LED dental light is equipped with a SENSOR/MANUAL mode selection switch.

Switching SENSOR mode and MANUAL mode can be changed by this switch.

Position of the SENSOR/MANUAL selection switch, see page 3 ~ 4 for [Overview and Major Components] section.

SENSOR mode : Touchless sensor is activated. The light can be changed treatment mode, composite mode by touchless sensor.

MANUAL mode : Touchless sensor is disabled. The light turning ON with high intensity.

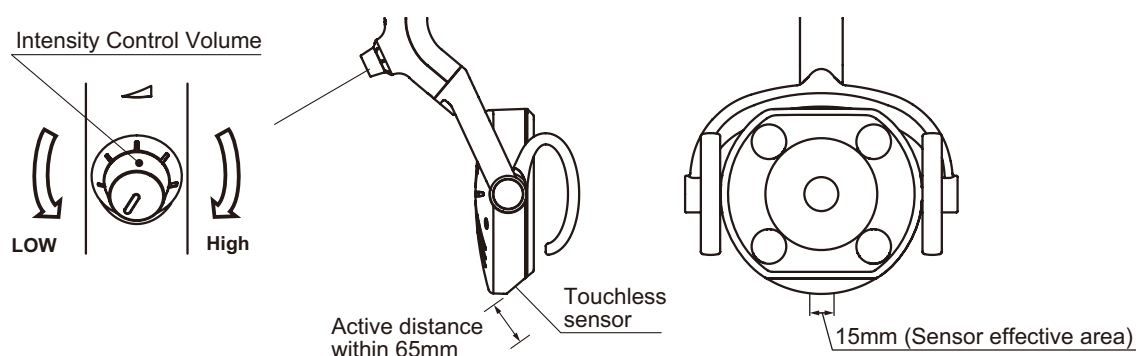

Description of Operation and Functions of Components

■ Operation

(1) Turn ON or OFF with Touchless Switch

The light can be turned on/off with a touchless switch. The sensor activates within the distance of 65mm from the surface. Let your hand pass by within 65mm from the touchless sensor to turn on the light.

Let your hand pass by again to turn off.

(2) SENSOR/MANUAL Mode Selection Switch

The SENSOR/MANUAL selection switch can be transition between two modes. [SENSOR] side for sensor mode, [MANUAL] side for manual mode.

(3) Mode Selection

During normal treatment mode, while the light is on, place and hold your hand within 65mm from the touchless sensor for certain time (2 seconds). The light intensity will be automatically reduced to the composite mode. To switch back to the normal treatment mode, place your hand by the touchless sensor for certain time (2 seconds) again.

Note: When the light is turned off in the composite mode, it goes on in the normal treatment mode when it is turned on again.

(4) Intensity control (Only for normal treatment mode)

It can adjust intensity between 3,100 ~ 28,000lux by step-less intensity control volume. The intensity is increased by turning intensity control volume clockwise. It is decreased by turning the intensity control volume counterclockwise. During composite mode, intensity can't be adjusted.

Care and Maintenance

■ Cleaning

Wipe the surfaces with dry and soft cloth. If the stain is hard to remove, wipe it off with the cloth moistened with 10% detergent solution diluted using water, be sure to wipe with dry cloth to wipe remaining moist.

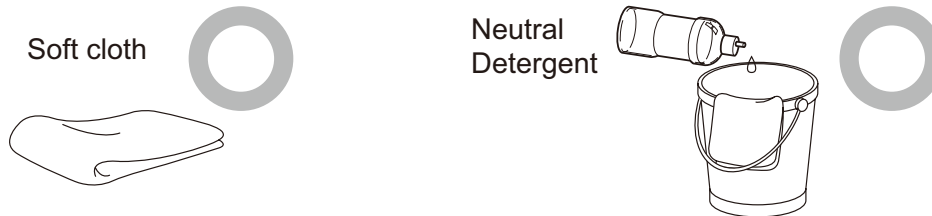

Never use the following for cleaning:

Volatile chemicals such as thinner, alcohol, gasoline, or kerosene, abrasive wax, abrasive sponges, etc. Some ethanol for disinfection may damage the surface. Always wipe off ethanol.

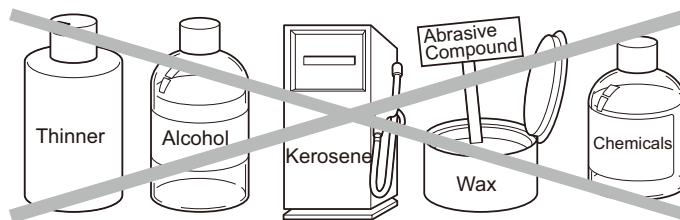

■ Disinfection of product exterior

Use FD366 made by Durr or ethanol as sprayed to a soft cloth or paper towel for cleaning and disinfection of the product exterior. Do not operate the product until the liquid used for disinfection has fully dried up.

Storage, Lifetime, Consumable, Stock Period of Parts and Disposal

■ Storage method

Strictly observe the following points when the product will not be used for a long period of time.

1. Main Switch

- Be sure to turn off the main switch at the end of each work day.
- Strictly observe this instruction to prevent electric accidents.

■ Lifetime

The durable period of this product is 10 years (self-certification based on in-house data), provided regular maintenance and inspection is done. However, parts requiring periodical maintenance have different durability periods. See the section on maintenance and inspection.

■ Consumable parts

The consumable parts are predicted to be abrasion, deterioration, and changes in external appearance or damage through use. Please note that repair or replacement of these parts is not covered by warranty, and fees will be required.

* The level and period of abrasion, deterioration or damage may differ depending on the usage environment and usage conditions of this product.

■ Stock period of parts

Our company will keep maintenance parts of the products such as consumables and periodical replacement parts, etc., for 10 years after sales.

Note : Maintenance parts means parts necessary for repair services for restoring the original conditions and functions of the product and maintaining those functions.

■ Disposing of equipment

In case of disposal of equipment or of components dismantled from the unit, take full infection preventing measures, and carry out appropriate steps in accordance with the legal regulations at that time.

Before Asking for Repairs

If any of phenomena described below has occurred, make the following checks before asking for repairs.

Phenomenon	Check point and result	Action to be taken
The light does not light up	Main switch is not on.	Turn on the main switch.
The light does not turn on/off from touchless switch	Confirm distance of a touchless switch.	Hand must pass by within 65mm from the touchless sensor surface.
	Touchless sensor surface is dirty.	Clean the touchless sensor surface.
The light intensity does not change	Light mode is set in composite mode	Change to normal treatment mode and try it again.
The light turned on/off its self	There is equipment having a mirror surface such as hand mirror around this product.	Remove the equipment having a mirror surface.
The light head movement (up/down, rotation) is tight.	The light has not been used for the last few days.	Move light head for three four times.

If the dental light does not normally work even if actions were taken upon checkup stated above, then stop using the unit, turn off the main switch and contact your dealer or our office.

WARNING

**Disassembly, repair or modifications should only be done by a qualified repair technician.
Attempts at disassembly, repair or modifications may lead to abnormal operation and accidents.**

Specifications

● Rated Voltage		
TYPE 301 • 302 • 305	: AC100 - 240V	50/60Hz
TYPE 320S	: DC 19V	
● Rated Input		
TYPE 301 • 302 • 305	: 0.15 - 0.29A	
TYPE 320S	: 0.72A	
● Fuse		
TYPE 301 • 302 • 305	: 250V 0.8A(T)	
● Light Source	: LED (5 LEDs)	
● Optical Performance	: Focal Distance	650mm
	: Light Intensity (Normal treatment mode)	3100 ~ 28000 Lux
	: Light Intensity (Composite mode)	4300 Lux
	: Correlated Color Temperature	5000K
● Light Pattern	: 85mm x 155mm	
● Protection class against electric shock	: Class I Equipment.	
● Usage environment	: Temperature	10 ~ 40°C
	Humidity	30 ~ 75%
	Air pressure	700 ~ 1060 hPa
● Transportation / Storage environment	: Temperature	-20 ~ 70°C
	Humidity	10 ~ 95%
	Air pressure	700 ~ 1060 hPa
● IEC60825-1 information	: Class 2 LED product	
	Product maximum output	11 mW
	Product emitted wavelengths	400 ~ 800 nm
	Product beam divergence	3.7°(h) / 6.5°(w)
	Internal LED maximum output	762 mW
	Internal LED emitted wavelengths	400 ~ 800 nm
	Internal LED beam divergence	120°

Specifications

● Dimensions

*Values are the standard values. (Unit: mm)

Dimensional tolerance: $\pm 10\%$

TYPE 301 Weight : 6.5kg

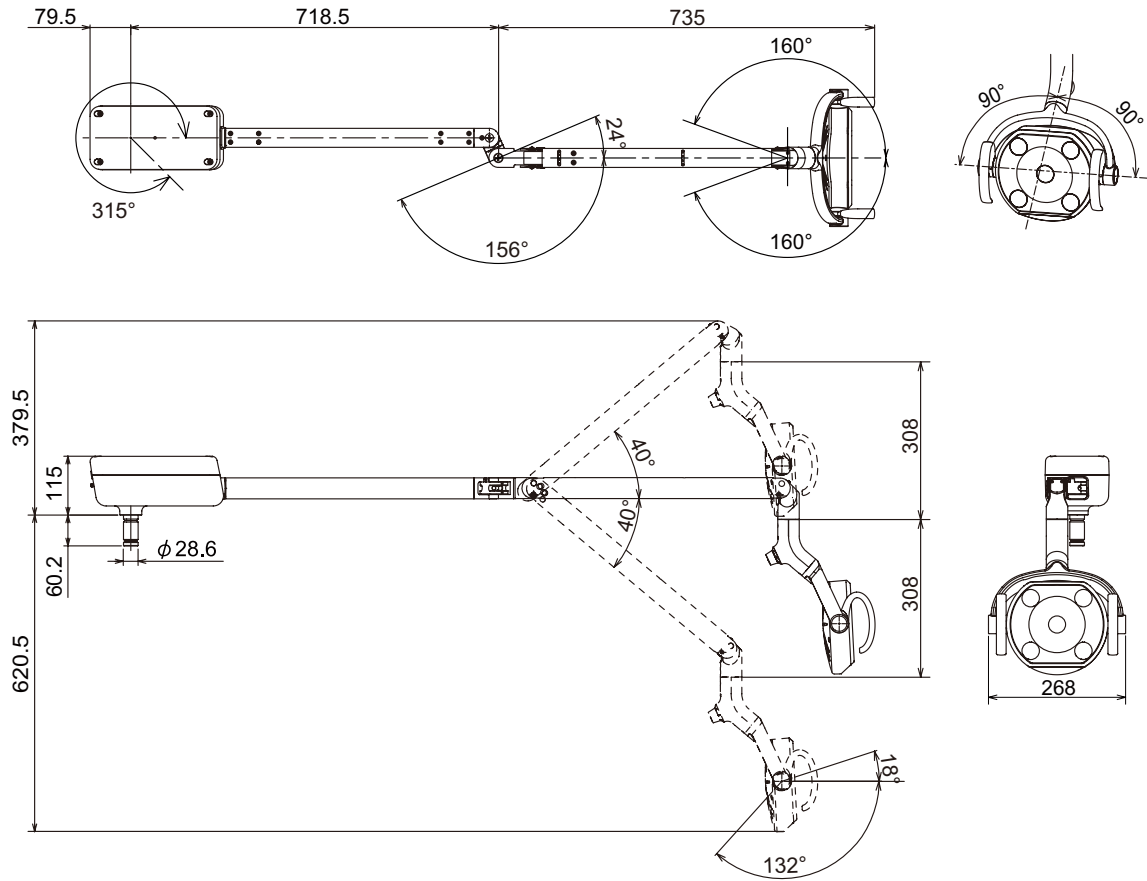

Specifications

● Dimensions

*Values are the standard values. (Unit: mm)

Dimensional tolerance: $\pm 10\%$

TYPE 302 Weight : 11 kg (with 340mm Standard Pole)

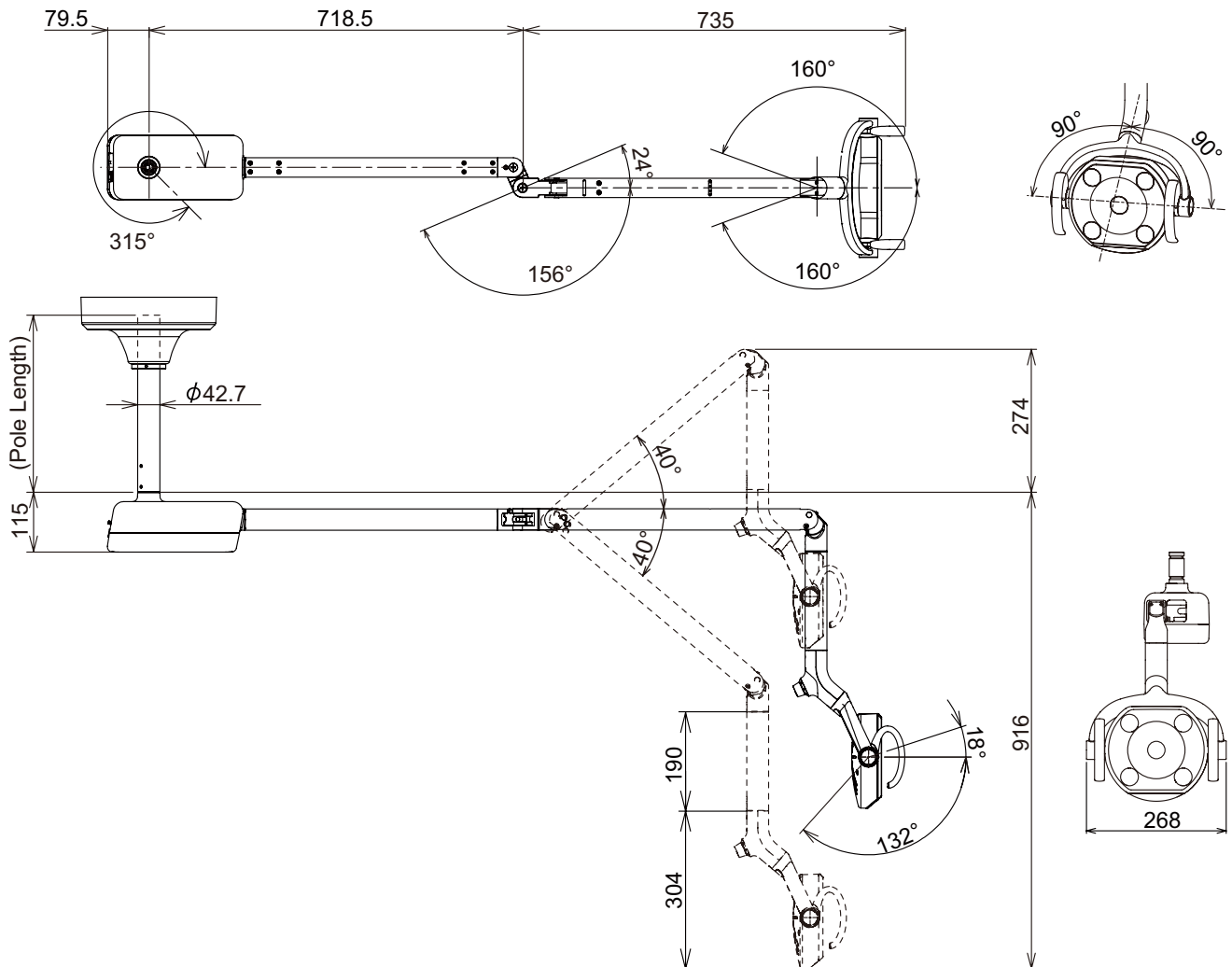

Specifications

● Dimensions

*Values are the standard values. (Unit: mm)

Dimensional tolerance: $\pm 10\%$

TYPE 305 Weight : 15kg (with 380mm Standard Pole)

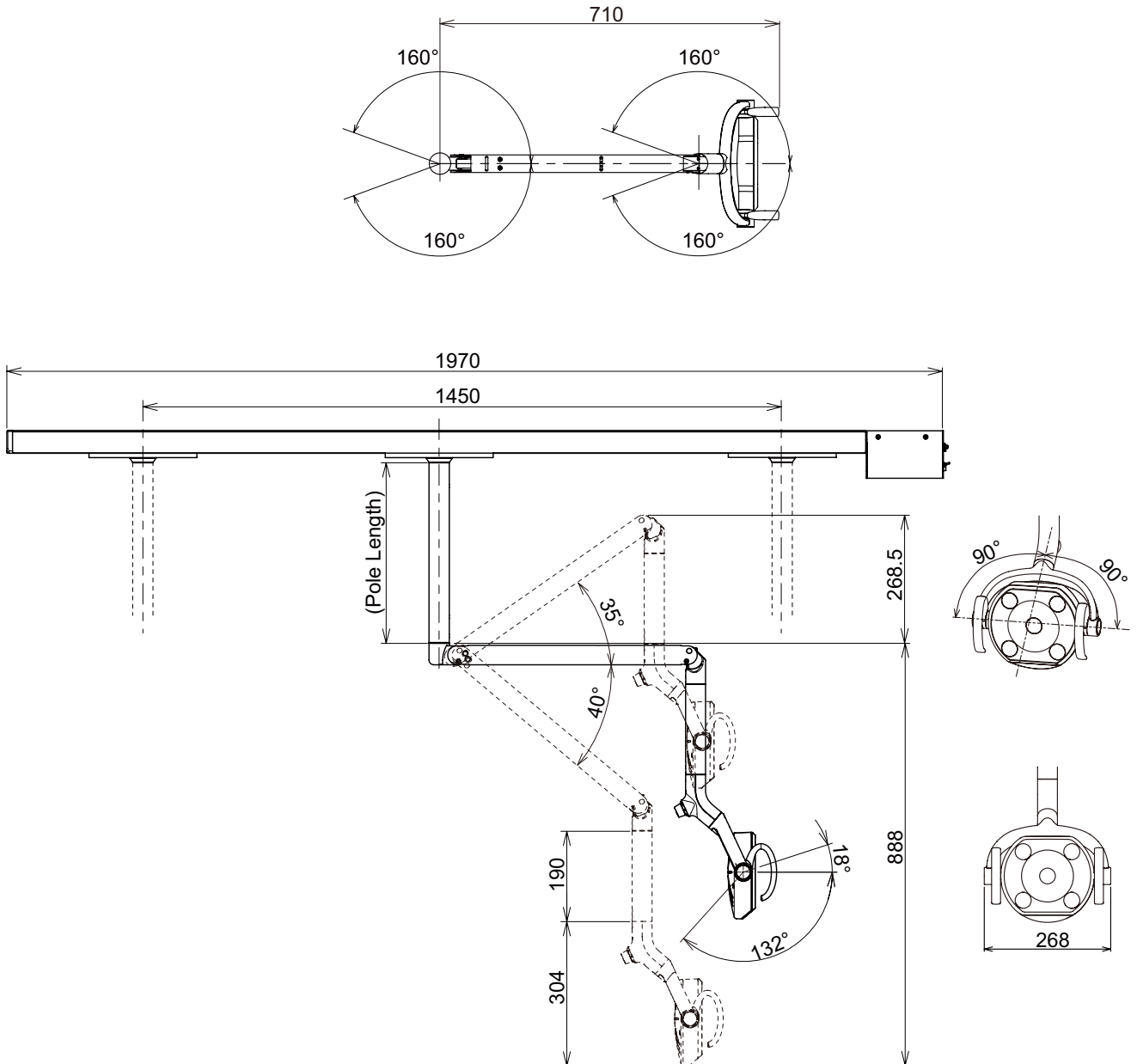

Specifications

● Dimensions

*Values are the standard values. (Unit: mm)

Dimensional tolerance: $\pm 10\%$

TYPE 320S Weight : 3.5kg

Product code : AL-320S*

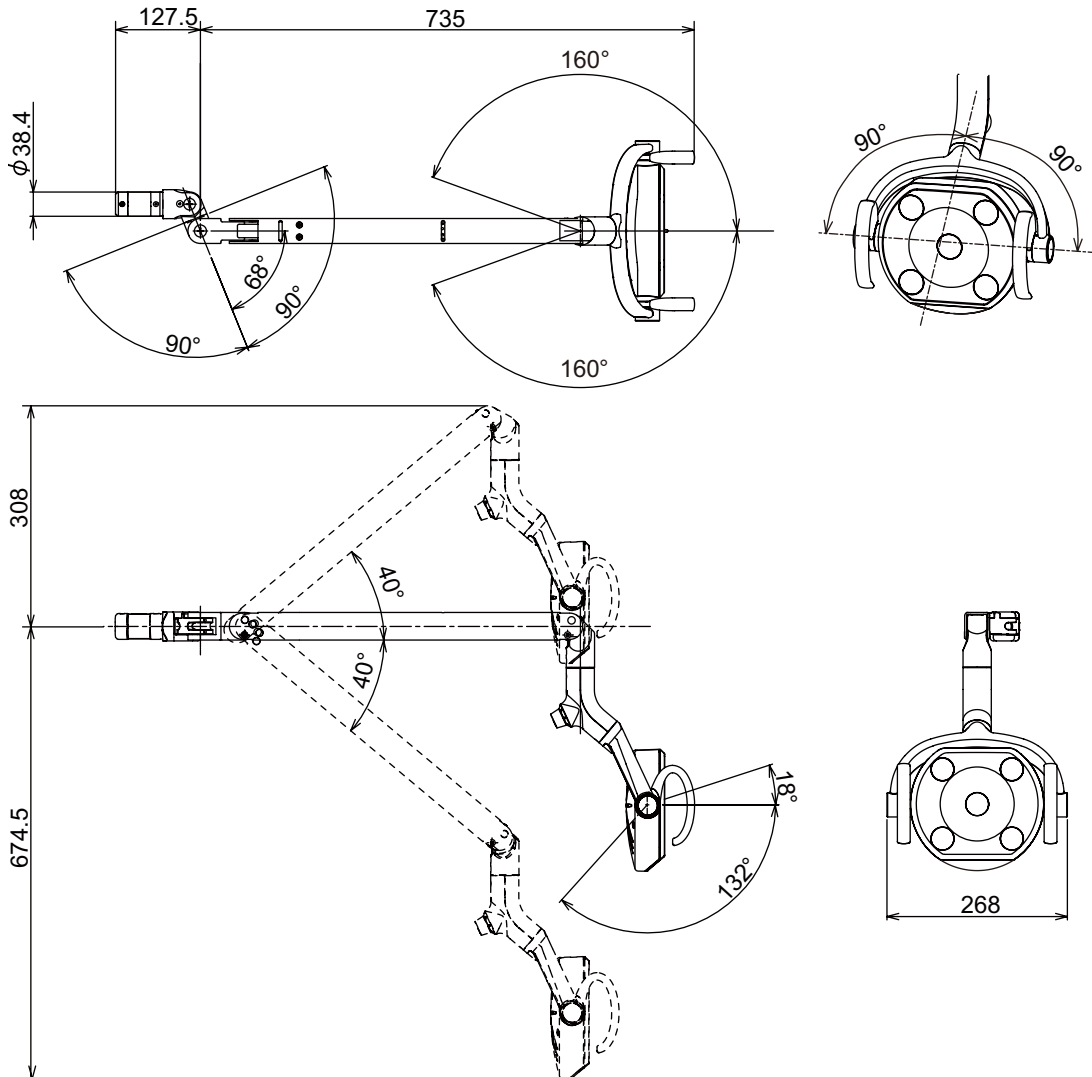

Product code : AL-320PAS* (Same as AL-320S except below figure)

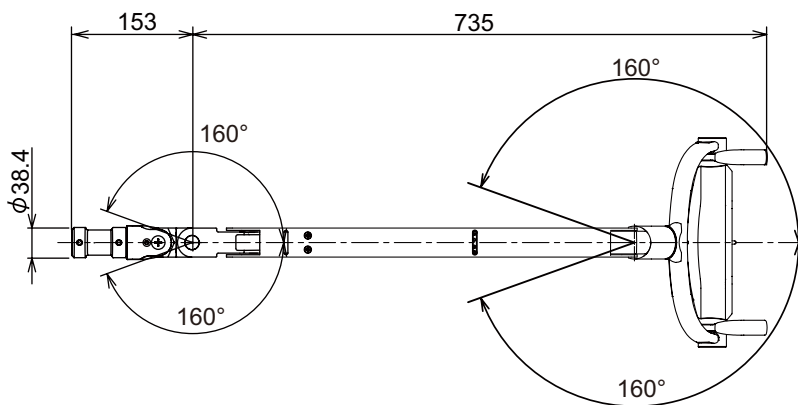

Maintenance and Inspection

Guide for daily maintenance and inspection (Maintenance and inspection by user)

- Management of maintenance and inspection of medical equipment should be implemented by the user (medical institution). In case the user does not implement such management, it is permitted that such management is outsourced to a qualified entity such as a medical equipment repair company.
- For safe use of this product, it is necessary that inspection should be conducted in the specified frequency on the items described below.

No.	Content inspection	Frequency	Inspection Method and diagnosis	Influence if inspection is not conducted	Maintenance required in case of nonconformity
1	Appearance of lens cover	Before start	Check deformation, scratches by eyes.	There is a possibility that the lens cover falls or deterioration of optical performance.	It may need replace the lens cover. Please contact your dealer or our office.
2	Touchless sensor	Before start	Confirm the light turns on, off and composite mode switching normally. It may not dirt of the sensor surface.	It may cause the difficulty at dental practice if the touchless sensor doesn't work.	The sensor surface may be dirty. Clean it with a soft cloth. If the sensor malfunctions after cleaning, please contact your dealer or our office.
3	Intensity control volume	Before start	Change intensity.	It may cause the difficulty at dental practice.	Turn off the light. Contact your dealer or our office.
4	Functionality of balance arm	Before start	Swing the balance arm up/down and right/left. Make sure the balance arm stops and holds its position.	Light head doesn't stay at the desired position.	Contact your dealer or our office.
5	Yoke joint cover	Before start	Confirm the yoke joint cover. It's not come out from balance arm. Make sure the yoke cover is securely fastened to the balance arm with two screws.	It may result in injury such as pinching a finger in a joint area if the yoke cover is not attached securely.	If unable to securely attach the yoke cover. Contact your dealer or our office.
6	Vertical rotation of the light head	Before start	Rotate the light head up/down. Make sure the light head stops and holds its position.	Light head doesn't stay at the desired position.	If the light malfunctions, Contact your dealer.
7	Light head angle	Before start	Confirms the light head is vertically aligned.	Light head doesn't stay at the desired position.	Adjust the angle of the light head.
8	Light head rotation	Before start	Rotate the light head right/left. Make sure the light rotate 160° to each direction.	Light head rotates freely. This may cause the snapping of a wire.	If the light malfunctions, contact your dealer or our office.
9	Movement of the trolley (Track light)	Before start	Check the movement of the trolley. Make sure the trolley run smoothly.	Light head doesn't stay at the desired position.	If the light malfunctions, contact your dealer or our office.
10	Track section (Track light)	Before start	Make sure that no wobble the track section when the product is operated.	There is a possibility that the light falls.	If the light malfunctions, contact your dealer or our office.
11	Moving Parts	Before start	Make sure that no abnormal noise occurs when the product is operated.	Light may not function right.	Turn off the light. Contact your dealer or our office.
12	If not used for a long time	Before start	If the light has not been used for a long time, make sure the light functions correctly and safely.	It may cause the difficulty at dental practice.	If the light malfunctions, Contact your dealer.
13	Care exterior	Before start	Chemical and dirt on the product exterior must be cleaned.	Discoloration and deterioration to the exterior, and corrosion and components may arise.	Executes wiping in accordance with "Cleaning Instructions"

Maintenance and Inspection

Guide for Periodical Check-up

- Some parts and components of the products are degraded or deteriorated depending on the frequency of use. Annual check-up and maintenance, as well as replacement of consumable parts, are required.
- The required parts (including consumable parts) are listed below. It may be different from the following list depending on the option of the unit.
- For check-up and repair, call a technician of our authorized dealer.

Parts and components that require periodical check-up

No.	Parts Description	Standard Lifetime
1	Light head moving part	8 years
2	Intensity control volume	7 years
3	Balance arm spring	7 years
4	Electric wires	4 years
5	Trolley for track light	4 years

Consumable parts

No.	Parts Description
1	Lens cover



Execute the maintenance in accordance with this instruction manual and operating manual attached to each individual equipment (Dental chair, Dental unit, etc..) .
Failure to maintain this product may lead to physical injury or property damage.

NOTE



TAKARA BELMONT CORPORATION

2-1-1, Higashishinsaibashi, Chuo-ku, Osaka, 542-0083, Japan

TEL : +81 6 6213 5945

FAX : +81 6 6212 3680

BOOK NO. 1E03JSD0

Printed in Japan. 2014-07