

## DENTAL CHAIR

# CREDIA *G1* CHAIR

## OPERATION INSTRUCTIONS

### IMPORTANT

- **This manual provides installation and operating instructions for the CREDIA G1 CHAIR.**
- **The instructions contained in this booklet should be thoroughly read and understood before operating the chair.**
- **After the installation has been completed, keep this manual in a safe place and refer to it for future maintenance.**
- **If you have any questions about this Manual or this product, please contact us. If manual becomes unreadable or is lost, please request a new manual by contacting your dealer.**
- **Installation should be conducted by authorized personnel only. Follow instructions on installation manual.**



# Table of Contents

<b>INTENDED USE OF THE PRODUCT</b>	
<b>IMPORTANT NOTES</b>	
<b>SYMBOLS</b>	
<b>SAFETY PRECAUTIONS</b>	<b>1~5</b>
<b>OVERVIEW AND MAJOR COMPONENTS</b>	<b>5</b>
<b>OPERATING INSTRUCTIONS</b>	
■ Twin Articulating Headrest . . . . .	6
■ Chair Operation . . . . .	6
<b>OPERATION STOPPING FUNCTION</b>	
■ Chair Operation Stopping Function . . . . .	7
<b>ARMREST ROTATION</b>	
■ Long Armrest Rotation (Optional) . . . . .	7
<b>CARE AND MAINTENANCE</b>	
■ Cleaning, Disinfection of product exterior . . . . .	8
<b>STORAGE, LIFETIME, CONSUMABLE, STOCK PERIOD OF PARTS AND DISPOSAL</b>	<b>9</b>
<b>BEFORE ASKING FOR REPAIRS</b>	<b>9</b>
<b>SPECIFICATIONS</b>	<b>10~11</b>
<b>MAINTENANCE AND INSPECTION</b>	<b>12</b>

## INTENDED USE OF THE PRODUCT

This product is an active therapeutic device intended for the exclusive use for diagnoses, treatments and relative procedures of dentistry.

The product must be operated or handled by the qualified dentists or by dental staffs under the supervision of the dentist.

Such dentists or dental staffs should instruct and/or assist the patients to approach to and leave from the product.

Patients should not be allowed to operate or handle the product unless he/she is so instructed.

## IMPORTANT NOTES

In case of the troubles, please contact Takara Belmont offices or your dealers.







Do not disassemble or attempt to repair.

Disassembly, repair or modifications should only be done by a qualified repair technician.

Attempts at disassembly, repair or modifications may lead to abnormal operation and accidents.

## SYMBOLS

Following symbols are used on the labels and in this manual of CREDIA G1 CHAIR. Confirm the meaning of each symbol.

	Alternating current		Protective earth (ground)		Manufacturer		Date of manufacture
	Type B Applied Parts		Refer to instruction manual/booklet				

# SAFETY PRECAUTIONS

- Before use, read the “Safety precautions” carefully to ensure proper use.
- The following information is designed to ensure safe use of this product and to prevent injury and damage to you and others. The precautions contained here are classified depending on the severity and degree of imminence of possible injury or damage resulting from improper use. Be sure to follow all the information, which is important for safety.













Classification of precautions	Severity and degree of imminence of possible injury or damage
<b>WARNING</b>	This symbol indicates that “ignorance of these precautions may lead to severe injury or even death as a result of improper use.”
<b>CAUTION</b>	This symbol indicates that “ignorance of these precautions may lead to mild or moderate physical injury or damage to property as a result of improper use.”
<b>NOTICE</b>	This symbol indicates that “it is recommended to follow these precautions for safety.”

The following symbols are used to explain the precautions.

Warning Symbols	Prohibition Symbols	Forcing Direction Symbols
Danger / Warning / Caution  Caution Fire  Caution electrical shock	General prohibition sign  Prohibit disassemble / repair	General sign  Earth / ground sign



# SAFETY PRECAUTIONS

## WARNING







 	<p><b>1. Be sure to turn off breakers for equipment in the clinic when this product will not be used for a long period of time</b></p> <p>Be sure to turn off breakers for equipment in the clinic when this product will not be used for a long period of time (following the completion of work, during the suspension of business, etc.). Insulation degradation may cause electrical fire.</p>
	<p><b>2. Be sure to turn off the main switch upon completion of work or during work breaks</b></p> <p>Be sure to turn off the main switch upon completion of work or during work breaks. This prevents incorrect operation due to accidental contact and associated hazards.</p>
	<p><b>3. Never disassemble, repair or modify this product</b></p> <p>Individuals other than certified repair technicians should not disassemble or attempt to repair and modify this product. This could lead to an accident, failure, electric shock or fire.</p>
 	<p><b>4. Be sure to establish a grounding connection</b></p> <p>Be sure to establish a proper grounding connection. (Refer to a vendor for grounding connection.) Failure or electric leakage may lead to electric shock.</p>
	<p><b>5. Use with caution in the presence of electromagnetic interference waves</b></p> <p>Do not place this product around equipment generating electromagnetic waves (including communications equipment, elevators, etc.) as incorrect operation of this product may occur in the presence of electromagnetic interference waves. Do not use equipment generating electromagnetic waves, such as mobile phones, around this product.</p>
	<p><b>6. Do not sit on other than seat</b></p> <p>When the backrest is at the forward position, do not sit on or place an undue load on the headrest or legrest of dental chair. This could cause the unit to topple or could damage the unit.</p>
	<p><b>7. Do not place an undue load on the arm</b></p> <p>Do not get on or place an undue load on the dental chair armrest. This could cause the unit to topple or other accidents.</p>
	<p><b>8. Immediately wipe off any water spills or leakage on the floor</b></p> <p>Immediately wipe off any water spills or leakage on the floor. Decreased strength of the floor may lead to physical injury including fall, or property damage.</p>
	<p><b>9. Be sure to turn off the main switch when electrocautery is in use</b></p> <p>Be sure to turn off the main switch when electrocautery is in use, because noise may cause incorrect operation of this product.</p>
	<p><b>10. Use with caution on patients with a cardiac pacemaker</b></p> <p>Use this product with extreme caution on patients with a cardiac pacemaker. In the case of any abnormalities in patients during use, immediately turn off this product and discontinue use.</p>
	<p><b>11. Pay attention during the headrest operation</b></p> <p>Do not allow hands, fingers, or hair to become entangled in the moving parts of the headrest during operation.</p>

# SAFETY PRECAUTIONS

## WARNING





	<p><b>12. Ensure the maintenance of this product</b></p> <ul style="list-style-type: none"> <li>• Failure to maintain this product may lead to physical injury or property damage.</li> <li>• Refer to the section of maintenance.</li> </ul>
	<p><b>13. Handling of equipment in the case of a power failure</b></p> <p>When power comes back after power failure, to avoid unexpected movement, follow below instructions.</p> <ul style="list-style-type: none"> <li>• Turn off the main power switch on dental unit.</li> <li>• If the chair stopped at elevated position, chair will not go down. Help a patient to get off from the chair while paying attention to avoid patient's injury. Pay attention the chair doesn't fall down.</li> </ul>

## CAUTION

	<p><b>1. Only experienced personnel should use this product</b></p> <p>Only dentists or other dental professionals should use this product.</p>
	<p><b>2. Confirm safety before use.</b></p> <p>Before use, confirm that the parts are correctly and safely operating and that there are no obstacles around this product.</p>
	<p><b>3. Pay attention to patients and children</b></p> <p>Keep your eyes on patients (especially, children) so that mischief or inadvertent operation of equipment will not lead to unexpected accidents.</p>
	<p><b>4. Discontinue use if you feel that "something is wrong"</b></p> <p>Always be careful to inspect this product for looseness, rattling, tilting, wobbling, sounds, temperature, odors, etc. Immediately discontinue use at the first feeling that "something is wrong."</p>
	<p><b>5. Do not smack or rub this product</b></p> <p>Do not smack or rub this product forcefully. This could cause damage to covers or defective function.</p>
	<p><b>6. Pay attention to contact injury during automatic operation</b></p> <p>Pay special attention to surroundings during automatic operation of the dental chair. Damage to the backrest, stool or Doctor's table may occur. Confirm that the patient is seated in the proper position and keep your eyes on the patient during operation.</p>

# SAFETY PRECAUTIONS

## CAUTION

	<p><b>7. Precautions for handling synthetic leather</b></p> <ul style="list-style-type: none"> <li>● Stain caused by clothing dyes The synthetic leather of this product may become stained by direct contact with clothes or belts. If there is stains, wipe clean as quickly as possible with a 10% detergent solution diluted using water to prevent permanent staining.</li> <li>● Take care of deformation or stains due to direct contact <ul style="list-style-type: none"> <li>• Direct contact with other objects such as plastic products, painted items, solvents or adhesive tape may cause changes to the surface luster, cracking, deformation or peeling.</li> <li>• Direct contact with newspaper or printed paper may cause stains.</li> <li>• Direct contact with items of clothing such as printed images of T-shirts, or jeans may cause discoloration of the synthetic leather of this product.</li> <li>• Direct contact with solvents such as benzene nail polish remover, alcohol may cause discoloration, melting of the surface, elution of the plasticizing agent, changes to surface luster, hardening/softening or peeling.</li> <li>• Using bleach or bleached sheets may cause changes to surface luster or discoloration.</li> <li>• Installing this product next to sources of excess heat such as irons or heaters may cause deformation or discoloration.</li> <li>• Protect this product from direct sunlight by installing curtains. Failure to follow this instruction may cause changes, shrinking, discoloration or fading of the leather surface.</li> <li>• Placing heavy objects for a long period of time may leave an imprint of wrinkles on the synthetic leather that cannot be removed.</li> </ul> </li> </ul>
	<p><b>8. Be sure to operate switches with your hands</b></p> <p>Be sure to operate switches with your hands, except the foot controller, which is operated with your foot. Operation with body parts other than hands may cause damage or incorrect operation.</p>
	<p><b>9. Immediately wipe off drug solution when it comes into contact with this unit</b></p> <p>Should drug solution or water comes into contact with this unit, immediately wipe it off with a dry soft towel, etc. This could result in defective function or electric leakage as well as spotting or rusting.</p>
	<p><b>10. Pay attention of the seating area</b></p> <p>Do not place any hard and heavy article or any article having a sharp tip or edge on the chair's seating area. The synthetic leather may be damaged otherwise.</p>
	<p><b>11. Precautions for cleaning the resin cover</b></p> <p>For cleaning, do not use cleaning agents containing solvent or abrasives, thinners or oil-based alcohol (butanol and isopropyl alcohol), which may cause cracks.</p>

## NOTICE

### 1. Troubleshooting and contact information

In the case of any problems, discontinue use, turn off the main switch and contact the dealer or our company.

# SAFETY PRECAUTIONS

## ■ Caution Points During Operation of the Product

### Description of Symbol Marks

- : Caution areas such as moving parts, rotating parts and detachable parts to which caution should be paid.
- ▷ : Caution areas that are provided with an emergency stop mechanism.

### Standard Armrest

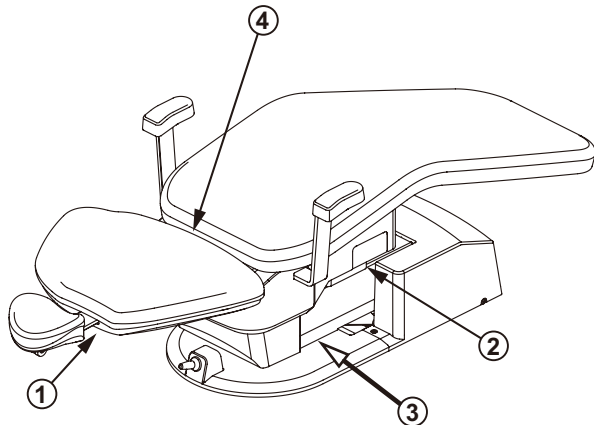

- ① **Take care not to be trapped by moving parts of the headrest.**  
Do not allow hands, fingers, or hair to become entangled in the moving parts of the headrest.
- ② **Take care not to be trapped by the lower part of the seat.**  
Do not put hands or feet into the gap in the lower part of the seat.
- ③ **Take care not to be trapped between the sub link cover and the base plate**  
Do not allow feet or obstruct between the sub link cover and the base plate.

### Long Armrest (Optional)

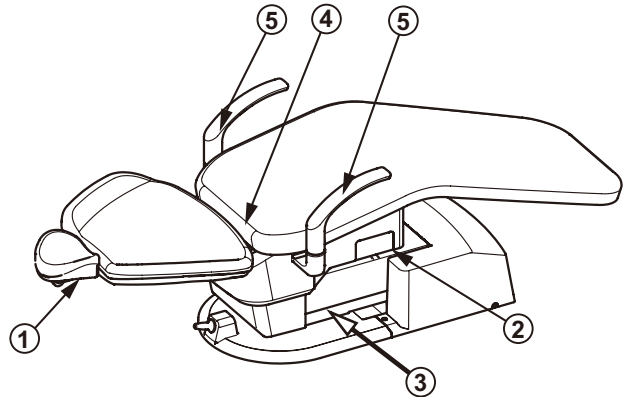

- ④ **Take care not to be trapped by moving parts of the backrest.**  
Do not put hands or feet into the gap between the backrest and the seat.
- ⑤ **Take care not to be trapped by the armrest.**  
Do not operate the chair with the armrest swing out 90 degrees.

# OVERVIEW AND MAJOR COMPONENTS

## ■ Overview and Major Components

### Standard Armrest

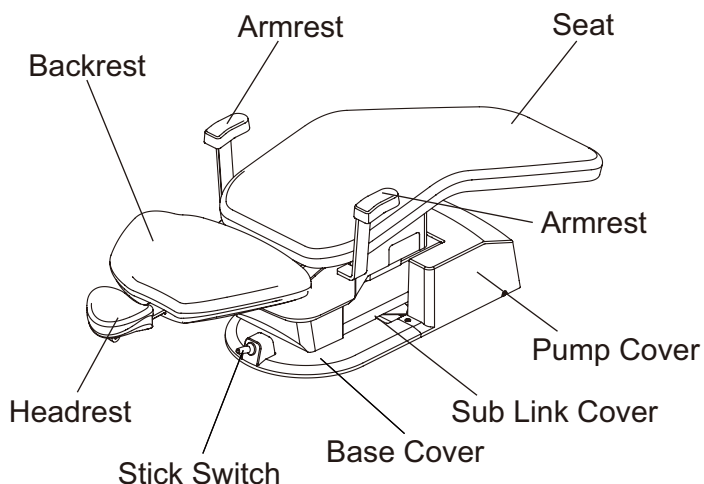

### Long Armrest (Optional)

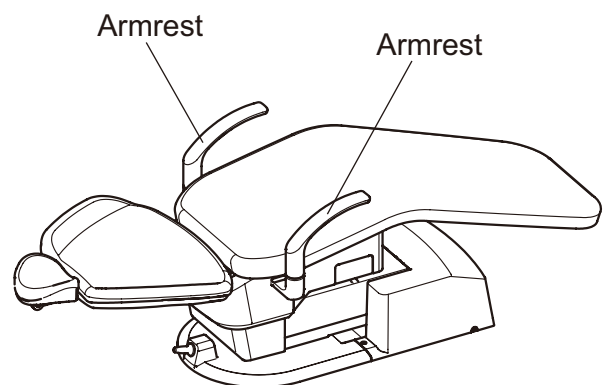



# OPERATING INSTRUCTIONS

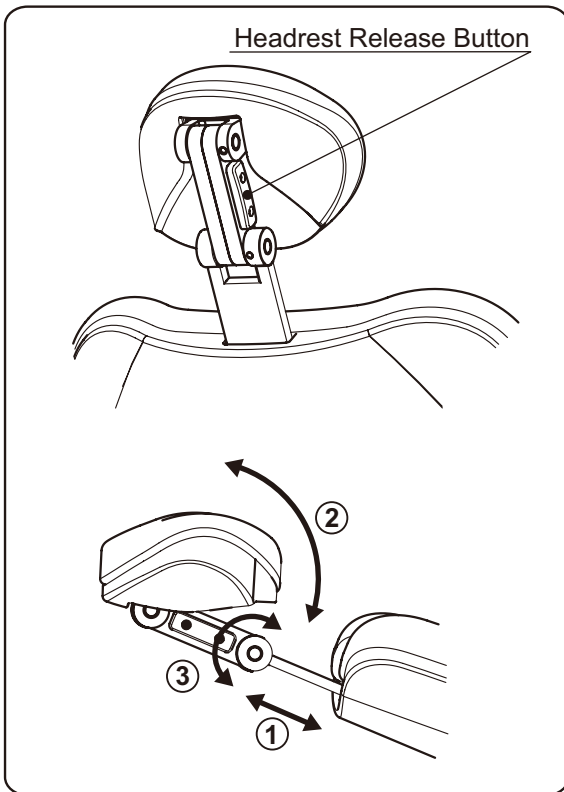

## ■ Twin Articulating Headrest

### ① Height Adjustment

Hold the headrest bar with both hands and adjust headrest height by pulling out or pressing down on the headrest bar.

### ② & ③ Angle Adjustment

Hold the headrest release button to unlock the twin axis mechanism and adjust headrest angle.

The headrest angle is locked when the headrest release button is released.

\* Does not move the right side release button of headrest, it is fixed.

## ⚠ WARNING

- Do not allow hands, fingers or hair to become entangled in the moving parts of the headrest.

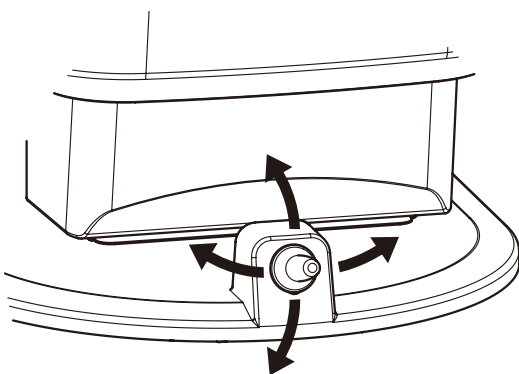

## ■ Chair Operation

- ▲ Keep depressing the stick switch upward until the seat is lifted up to the desired position.
- ▼ Keep depressing the stick switch downward until the seat is lowered to the desired position.
- ◀ Keep depressing the stick switch to left side until the backrest is reclined to the desired position.
- ▶ Keep depressing the stick switch to right side until the backrest is raised up to the desired position.

## ⚠ CAUTION

- Confirm that the patient is seated in the proper position before operation of the chair and keep your eyes on the patient during operation.
- Before operating the chair, confirm that there are no obstacles around this product.

## OPERATION STOPPING FUNCTION

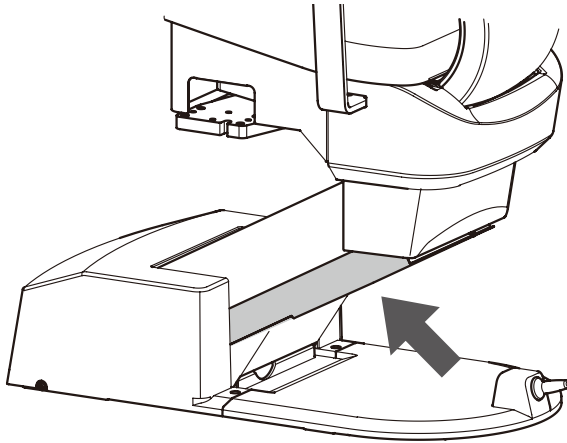

### ■ Chair motion stop function (safety function)

When pressure is detected between the base and the sub link cover. The chair will moving up for a certain period of time and stopped automatically.

## ARMREST ROTATION

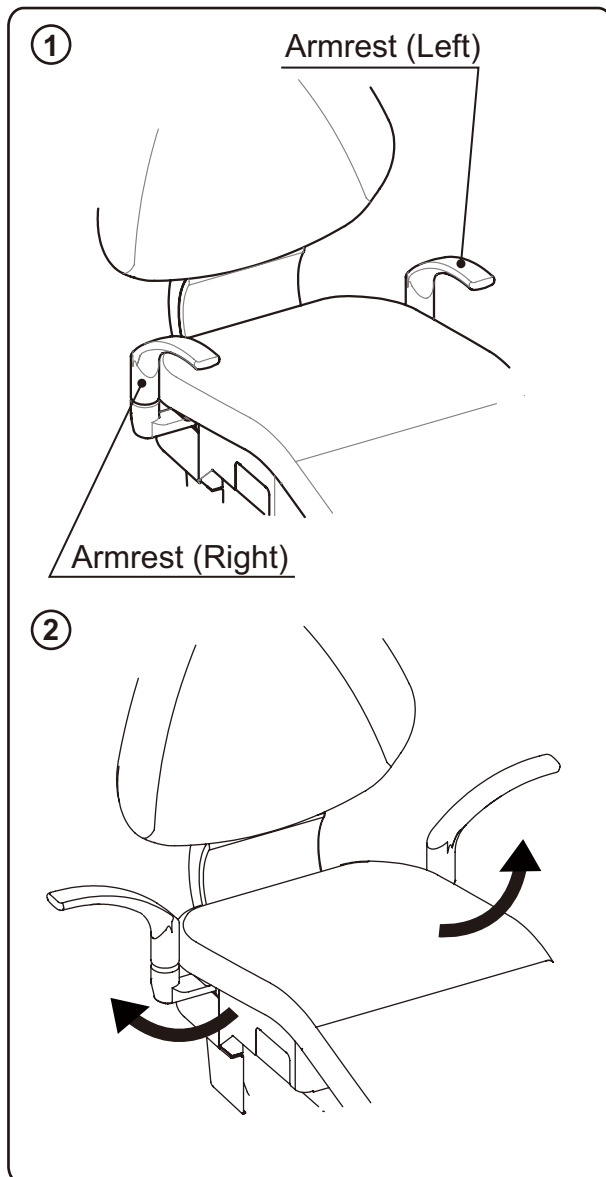

### ■ Long Armrest Rotation (Optional)

The long armrest (left) and the long armrest (right) can be rotated outward 90 degrees.

## CARE AND MAINTENANCE

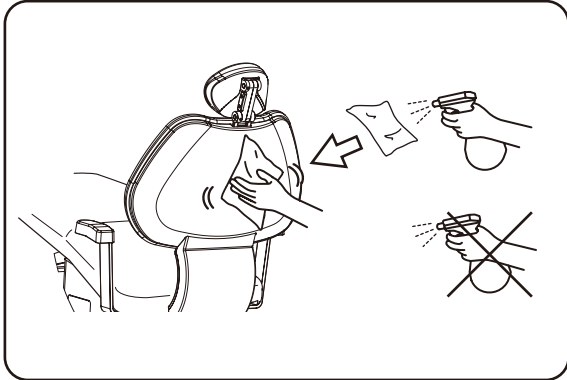

### ■ Chair Cleaning and Disinfection

- The surface of the chair's seating area is made of synthetic leather. Apply dry wiping or wipe the surface with cloth moistened with a 10% detergent solution diluted using water. In case the synthetic leather is wiped with a wet cloth, fully wipe off the moisture with dry cloth.
- If the color of clothing or belt remained on the synthetic leather, wipe it off with cloth moistened with a 10% detergent solution diluted using water as soon as possible, to avoid penetration caused by plasticizer.
- In case the synthetic leather is wiped with a wet cloth, fully wipe off the moisture. If it remains, hydrolytic degradation may be accelerated. Do not use solvent bleach.
- Use FD366 made by Durr for cleaning and disinfection of the product exterior.
- Apply dry wiping using a dry and soft cloth to metallic and resin cover areas.

### **!** CAUTION

- **If there is stains, wipe clean as quickly as possible with a 10% detergent solution diluted using water to prevent permanent staining and fully wipe off the moisture with dry and soft cloth.**
- **For cleaning the resin cover, do not use cleaning agents containing solvent or abrasives, thinners or oil-based alcohol (butanol and isopropyl alcohol), which may cause cracks.**
- **If any metallic area is wetted, wipe off the moisture as soon as possible. They may facilitate rust generation.**

### **!** CAUTION

**Do not place any hard and heavy article or any article having a sharp tip or edge on the chair's seating area. The synthetic leather may be damaged otherwise.**

## STORAGE, LIFETIME, CONSUMABLE, STOCK PERIOD OF PARTS AND DISPOSAL

### ■ Storage method

Strictly observe the following points when the product will not be used for a long period of time.

1. Turn OFF the main switch at the lowest seat position and backrest reclining position after daily operation and for a long term interval.
2. Be sure to turn off the main switch at the end of each work day.
3. Be sure to turn off the equipment breaker on the clinic's electrical panel.

### ■ Lifetime

The durable period of this product is 10 years (self-certification based on in-house data), provided regular maintenance and inspection is done. However, parts requiring periodical maintenance have different durability periods. See the section on maintenance and inspection.

### ■ Consumable parts

The consumable parts are predicted to be abrasion, deterioration, and changes in external appearance or damage through use. Please note that repair or replacement of these parts is not covered by warranty, and fees will be required.

\* The level and period of abrasion, deterioration or damage may differ depending on the usage environment and usage conditions of this product.

### ■ Stock period of parts

Our company will keep maintenance parts of the products such as consumables and periodical replacement parts, etc., for 10 years after sales.

Note : Maintenance parts means parts necessary for repair services for restoring the original conditions and functions of the product and maintaining those functions.

### ■ Disposing of equipment

In case of disposal of equipment or of components dismantled from the unit, take full infection preventing measures, and carry out appropriate steps in accordance with the legal regulations at that time.

## BEFORE ASKING FOR REPAIRS

If any of phenomena described below has occurred, make the following checks before asking for repairs.

Phenomenon	Check point and result	Action to be taken
The product does not work at all.	Main switch is not on.	Turn on the main switch.
	Equipment circuit breaker in the clinic cabinet panel is not on.	Turn on the equipment circuit breaker.

If the unit does not normally work even if actions were taken upon checkup stated above, then stop using the unit, turn off the main switch and contact your dealer or our office.

### WARNING

**Individuals other than certified repair technicians should not disassemble or attempt to repair and modify this product. This could lead to an accident, failure, electric shock or fire.**

# SPECIFICATIONS

- **Control No.** : AC-CR1-C ① V-②, AC-CR1-C ① V ② L  
(①: Voltage, ②: Frequency)  
This product power is supplied from CREDIA G1
- **Rated power supply**
  - : AC110V 60 Hz, 4.0A
  - : AC120V 60 Hz, 4.4A
  - : AC220V 50/60 Hz, 1.7A/1.7A
  - : AC230V 50/60 Hz, 1.9A/1.7A
  - : AC240V 50 Hz, 2.2A
- **Weight** : 130kg
- **Patient capacity** : 200kg
- **Mode of operation** : Non-Continuous Operation  
Duration of Maximum Operating Time : 1min,  
Duty Cycle 1 : 20
- **Protection class against electric shock** : Class I equipment
- **Applied part** : type B applied part: Seat for chair
- **Usage environment**
  - : Temperature 10 to 40°C
  - Humidity 30 to 75%
  - Air pressure 700 to 1060 hPa
- **Transportation / Storage environment**
  - : Temperature -20 to +70°C
  - Humidity 10 to 95%
  - Air pressure 700 to 1060 hPa

# SPECIFICATIONS

## Dimensions

\* Values are the standard values. (Unit: mm)

Dimensional tolerance:  $\pm 10\%$

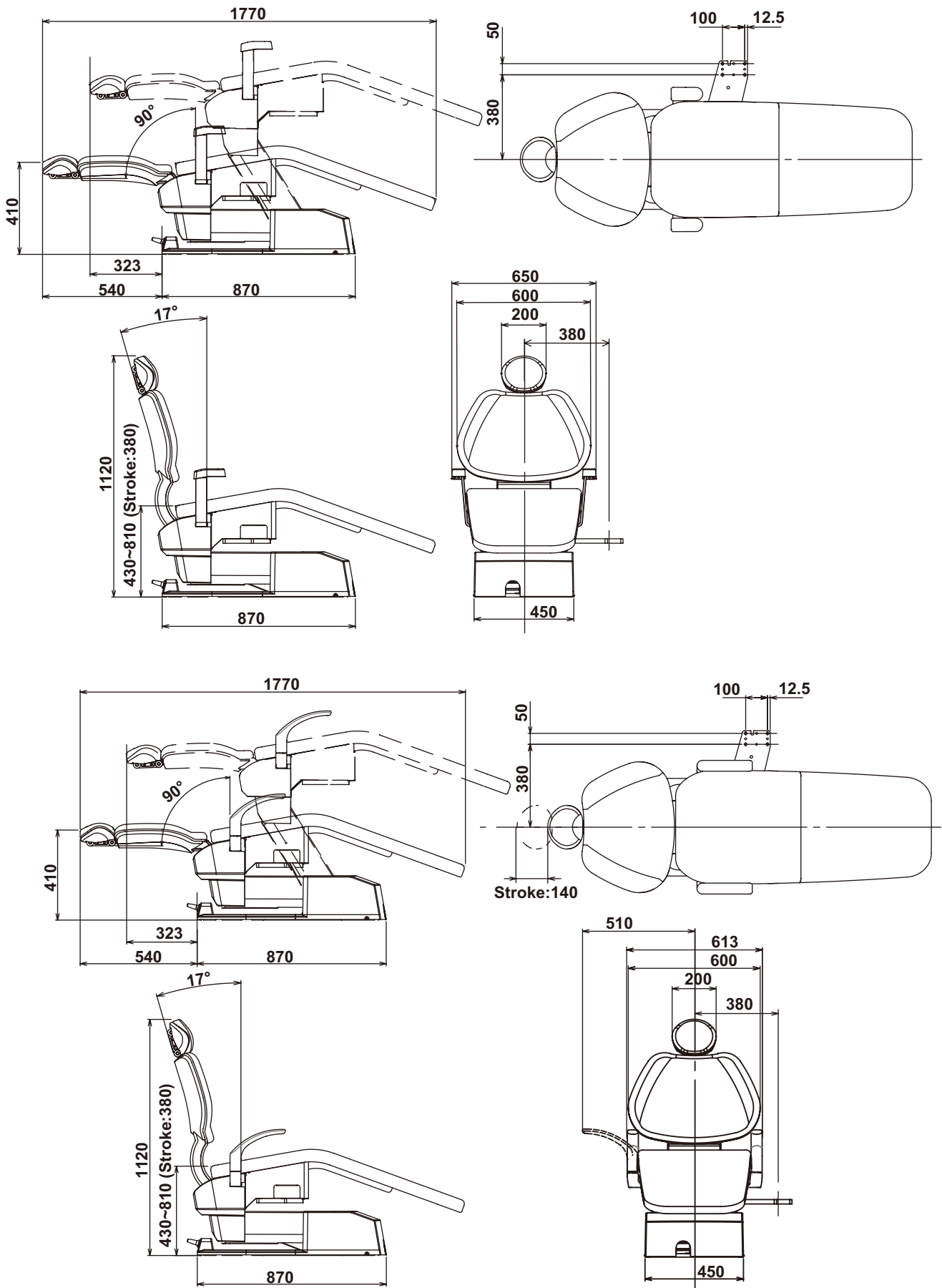

# MAINTENANCE AND INSPECTION

## Guide for daily maintenance and inspection (Maintenance and inspection by user)

- Management of maintenance and inspection of medical equipment should be implemented by the user (medical institution). In case the user does not implement such management, it is permitted that such management is outsourced to a qualified entity such as a medical equipment repair company.
- For safe use of this product, it is necessary that inspection should be conducted in the specified frequency on the items described below.

No.	Item	Frequency	Inspection method and diagnosis	Influence if inspection not conducted	Maintenance required in case of nonconformity
1	Check of safety functions	Before start	Make sure the chair movement stops by any of the following actions. 1. During chair auto movement, depress of any operation switch. 2. When push the chair link cover.	Unexpected personal injury and troubles may arise due to motion of the chair during medical treatment and due to pinching between doctor section and chair.	Contact your dealer or our office if any abnormality arises.
2	Product's moving parts	Once every week	No abnormal noise or the like shall be produced from product's moving parts when the product is operated.	The product will not normally work and troubles may arise.	Contact your dealer or our office if any abnormality arises.

## Guide for Periodical Check-up

- Some parts and components of the products are degraded or deteriorated depending on the frequency of use. Annual check-up and maintenance, as well as replacement of consumable parts, are required.
- The required parts (including consumable parts) are listed below. It may be different from the following list depending on the option of the unit.
- For check-up and repair, call a technician of our authorized dealer.

### Parts and components that require periodical check-up

No.	Parts Description	Standard Lifetime
1	Spring (Include a spring hook)	5 years
2	Hydraulic moving part (O-ring, Packing)	5 years
3	Electric wiring of moving part	5 years
4	Switches	5 years
5	Solenoid Valve	7 years

## **WARNING**

**Execute the maintenance in accordance with this instruction manual and operating manual attached to each individual equipment ( Dental light, Handpiece, etc..) .  
Failure to maintain this product may lead to physical injury or property damage.**

**NOTE**

 **Belmont**



**BELMONT MANUFACTURING CO., LTD. (Manufacturer)**

Long Duc Industrial Park,  
Long Thanh District, Dong Nai Province, Viet Nam  
TEL : +84-613-201-100 / FAX : +84-613-201-096

**TAKARA BELMONT CORPORATION**

2-1-1, Higashishinsaibashi, Chuo-ku, Osaka, 542-0083, Japan  
TEL : +81-6-6213-5945 / FAX : +81-6-6212-3680  
[www.takara-net.com](http://www.takara-net.com)

BOOK NO. 1E03Q1C0  
Printed in Vietnam. 2014-06