

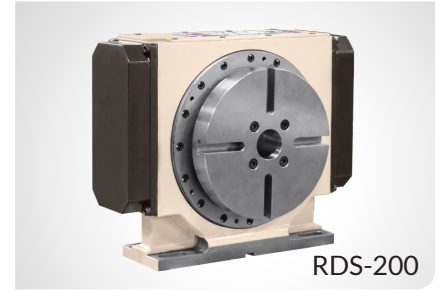



RDS-200

SLIM FOOTPRINT • DIRECT DRIVE MOTOR

This series utilizes Tsudakoma's proprietary direct drive motor system enabling the rotary table to achieve high speed and acceleration with no backlash. The RDS-200 model is a compact single axis 300 rpm direct drive rotary table with indexing accuracy of ± 10 arc seconds and a strong pneumatic braking system.



RDS-200

Table Model		RDS-200
Spindle outer diameter	mm	83H7
Center height	mm	160
Center bore	Nose Diameter	55H7
	Thru Diameter	45H7
Servo motor (For Fanuc)*		Tsuda-02
Speed reduction ratio		1/1
Maximum table speed	rpm	300
Clamp system		Pneumatic
Holding torque @72psi	Nm (ft. lbs.)	600 (443)
Indexing accuracy	arc sec.	± 10
Net Weight	kg (lbs.)	65 (144)
Allowable work weight	 kg (lbs)	100 (220)
Allowable Load when table clamped	 N	6,860
	 Nm	600
	 Nm	350

* Other motors & RPM available
 ** Booster optional
 Specifications subject to change without notice

Dimensions

Drawings not to scale • Dimensions = mm

RDS-200

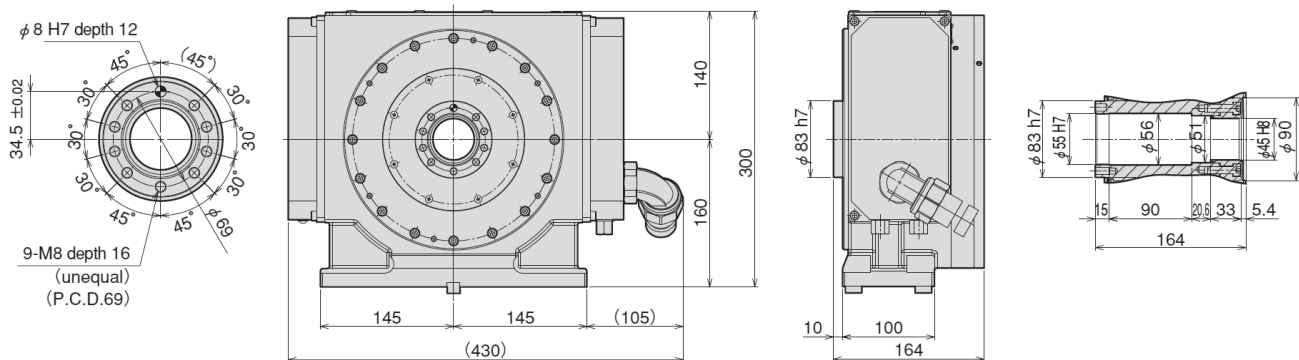

The dimensions above are for tables with a FANUC servo motor. Other motors available (dimensions may increase).