

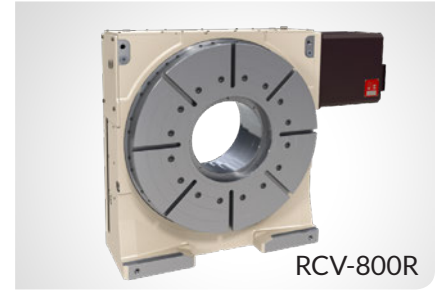





**RCV-800R, 1000R, 1250R**

HIGH CAPACITY • LARGE THRU HOLE

The RCV-Series rotary tables feature an extra large thru hole for accommodating large workpieces. The RCV-800 can be equipped with either an 800mm or an optional 1,000mm face plate, and the RCV-1000 can hold either a 1,000mm or an optional 1,200mm face plate.



RCV-800R

Table Model		RCV-800R	RCV-1000R	RCV-1250R
Table diameter (optional)	mm	800 (1,000)	1,000 (1,200)	1,250 (1500)
Center height	mm	530	625	775
Center bore	Nose Diameter	360H7 x 45	410H7 x 75	500H7 x 25
	Thru Diameter	310	360	450
Table T-slot width		18H7	22H7	22H7
Guide block width		22h7		
Servo motor (Fanuc)*		Alpha 12i	Alpha 22i	Alpha 22i
Maximum motor speed		rpm	4,000	3,000
Speed reduction ratio		1/360		1/720
Maximum table speed		rpm	11.1	8.33
Inertia converted into motor shaft		x 10 <sup>-3</sup> kg·m <sup>2</sup>	4.89	12.2
Clamp system**		Hydraulic		
Clamp torque @500psi		Nm (ft. lbs.)	7,000 (5,159)	20,000 (14,740)
Indexing accuracy		arc sec.	±7.5	
Net Weight		kg (lbs.)	1,450 (3,190)	2,500 (5,500)
Allowable wheel torque		Nm (ft. lbs.)	7,840 (5,778)	13,230 (9,751)
Allowable work inertia		kg·m <sup>2</sup>	120	874
Allowable work weight	 <b>kg (lbs)</b> [w/ tailstock]	2,000 (4,400) [4,000 (8,000)]	3,500 (7,700) [7,000 (15,400)]	6,300 (13,860) [13,860(30,492)]
	 <b>kg (lbs)</b>	4,000 (8,800)	7,000 (15,400)	13,860 (30,492)
Allowable load when table clamped	 <b>N (lbf)</b>	100,000 (22,400)	185,000 (41,440)	383,000 (85,792)
	 <b>Nm (ft. lbs.)</b>	7,000 (5,159)	20,000 (14,740)	33,000 (24,321)
	 <b>Nm (ft. lbs.)</b>	11,600 (8,550)	22,900 (16,877)	56,700 (41,788)

\* Other motors & RPM available

\*\* Booster optional

Specifications subject to change without notice

Dimensions

Drawings not to scale • Dimensions = mm

RCV-800R

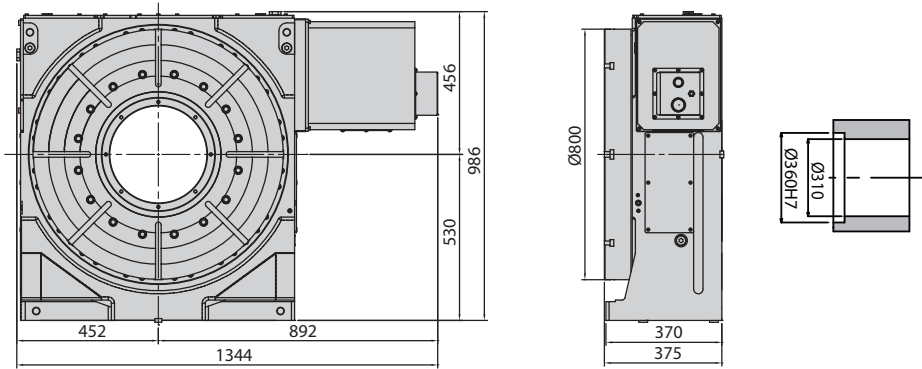

RCV-1000R

Shown with 1200mm faceplate.

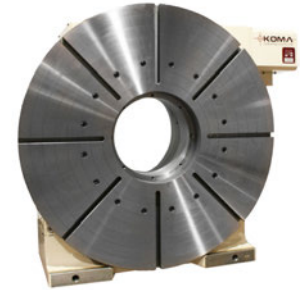

RCV-1000R

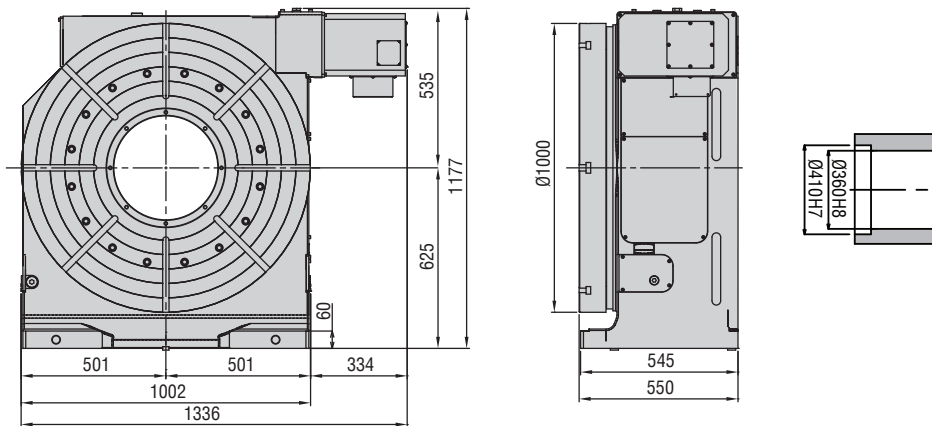

RCV-1250R

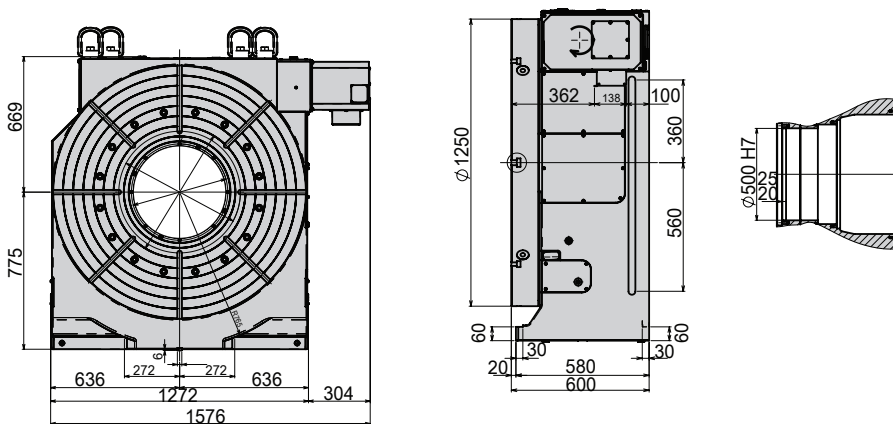

Options & Accessories

TPC NC Controller	p.68
Chucks	p.79
Tailstock	p.81
Support Spindle	p.81
Face Plate	p.83
Encoder / Scale	p.84
Pull Stud Device	p.85
Rotary Joint	p.85
PVC or Steel Cables	p.86

The dimensions above are for tables with a FANUC servo motor. Other motors available (dimensions may increase).

Clamping Block and Bolt

Dimensions = mm

	Type	Q'ty	T-Slot Width	A	B	C	D	E	F	G	H	I	J	K	L	M
RCV-800R	II	4	22	60	28	95	29	16	50	88	27	13	145	100	32	20
RCV-1000R	II	4	22	60	28	95	29	16	50	88	27	13	145	100	32	20
RCV-1250R	II	8	22	60	28	95	29	16	50	88	27	13	145	100	32	70

Note: When using a machine with a T-slot pitch other than the above, use suitable clamping blocks and bolts that are available on the market, or order custom-made ones from KOMA (opt.)

Type II

