

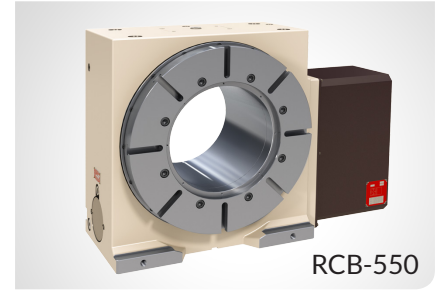



# RCB-350, 450, 550

HIGH RIGIDITY • DIRECT DRIVE MOTOR

The RCB-Series rotary tables feature a extra large center bore. RCB tables utilize a powerful dual disc hydraulic clamping mechanism. Ideal for Energy manufacturing.



RCB-550

Table Model		RCB-350	RCB-450	RCB-550
Versions available		R, L	R, L	R, L
Table diameter		350	450	550
Center height		255	310	350
Center bore	Nose Diameter	245H7	295H7	345H7
	Thru Diameter	215	265	315
Table T-slot width		14H7	14H7	18H7
Guide block width		18H7	18H7	18H7
Servo motor*		Alpha 12i	Alpha 22i	Alpha 22i
Maximum motor speed rpm		4,000	3,000	3,000
Speed reduction ratio		1/90	1/90	1/120
Maximum table speed rpm		44.4	33.3	25
Inertia converted into motor shaft x 10 <sup>-3</sup> kg-m <sup>2</sup>		3.48	6.14	6.01
Clamp system**		Hydraulic	Hydraulic	Hydraulic
Clamp torque @500psi Nm (ft. lbs.)		3,300 (2,432)	4,700 (3,464)	6,500 (4,790)
Indexing accuracy arc sec.		±7.5	±7	±7.5
Net Weight kg (lbs.)		400 (880)	520 (1,144)	720 (1,584)
Allowable wheel torque Nm (ft. lbs.)		1,942 (1,431)	3,276 (2,414)	4,716 (3,475)
Allowable work inertia kg-m <sup>2</sup>		6.1	17.7	37.8
Allowable work weight	 kg (lbs)	400 (880)	700 (1,540)	1,000 (2,200)
Allowable load when table clamped	 N (lbf)	29,400 (6,586)	45,000 (10,080)	54,000 (12,096)
	 Nm (ft. lbs.)	3,300 (2,432)	4,700 (3,464)	6,500 (4,790)
	 Nm (ft. lbs.)	3,626 (2,672)	8,000 (5,896)	15,132 (11,152)

\* Other motors & RPM available  
 \*\* Booster optional  
 Specifications subject to change without notice

## Dimensions

Drawings not to scale • Dimensions = mm

### RCB-550

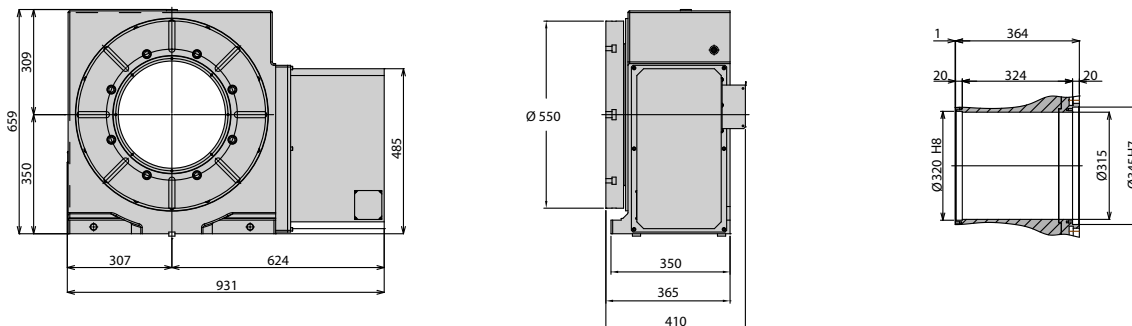

The dimensions above are for tables with a FANUC servo motor. Other motors available (dimensions may increase).