

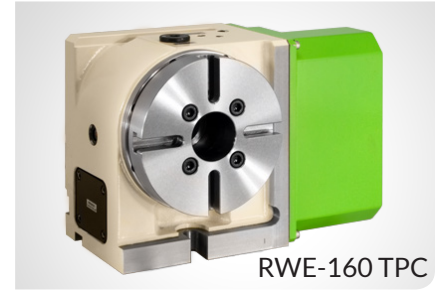





RWE-160 TPC, 200 TPC

PACKAGED WITH CONTROLLER FOR PLUG & PLAY OPERATION

RWE-Series indexers are packaged with a TPC-Jr NC controller for plug & play operation. The RWE indexers are attractively priced, yet retain the high performance build characteristics found on full 4th axis Tsudakoma rotary tables.



Indexer Model		RWE-160 TPC	RWE-200 TPC
Spindle outer diameter		100h7	120h7
Table diameter (optional)		(160 or 200)	(200 or 250)
Center height		135	160
Center bore	Nose Diameter (w/ face plate)	55H7 (50H7)	65H7 (60H7)
	Thru Diameter	40	45
Table T-slot width w/ face plate		12H8	12H8
Guide block width		14h7	18h7
Controller (included with table)		TPC-Jr G2	TPC-Jr G3
Maximum motor speed rpm		3,000	
Speed reduction ratio		1/60	1/72
Maximum table speed rpm		50	41.7
Inertia converted into motor shaft x 10 ⁻³ kg·m ²		.19	.19
Clamp system		Pneumatic	
Clamp torque @72psi Nm (ft. lbs.)		156 (115)	294 (217)
Indexing accuracy arc sec.		±22.5	
Net Weight kg (lbs.)		40 (88)	65 (143)
Allowable wheel torque Nm (ft. lbs.)		147 (108)	264 (195)
Allowable work inertia kg·m ²		.48	1.2
Allowable work weight	 kg (lbs) [w/ tailstock]	75 (165) [150 (330)]	100 (220) [250 (550)]
	 kg (lbs)	150 (330)	250 (550)
Allowable load when table clamped	 N (lbf)	7,840 (1,756)	13,720 (3,073)
	 Nm (ft. lbs.)	156 (115)	294 (217)
	 Nm (ft. lbs.)	392 (289)	980 (722)

Controller		TPC-Jr		
Control axis		1 axis		
Servo motor		AC servo, ABS detector		
Command unit		0.001°		
Dividing number	Direct indexing	1 to 999999 even indexing		
	Arc indexing	1 to 999 even indexing		
Max. command angle		± 999.999°		
Command system		INC, ABS, Shortcut ABS, INC/ABS mixed system		
Input system		Includes MDI & full RS-232 communication		
Program control		Workpiece No. (W0000 to 9999)		
Program capacity		1000 blocks in main & sub-program together		
Cable supplied (Standard)		Between rotary table & TPC-Jr (1 pc.)		
		For motor : 5m		
		Power cable : 5m		
Power Requirements (less than 100 ohm ground resistance)		1 Ø 200/220V±10% 50/60Hz (non-CE)		
		1 Ø 230V±10% 50/60Hz (CE)		
		Model	Power capacity	Fuse Rating
		Jr H2	1.2KVA	8A
Jr H3	2.2KVA	15A		

Specifications subject to change without notice

Dimensions

Drawings not to scale • Dimensions = mm

RWE-160 TPC

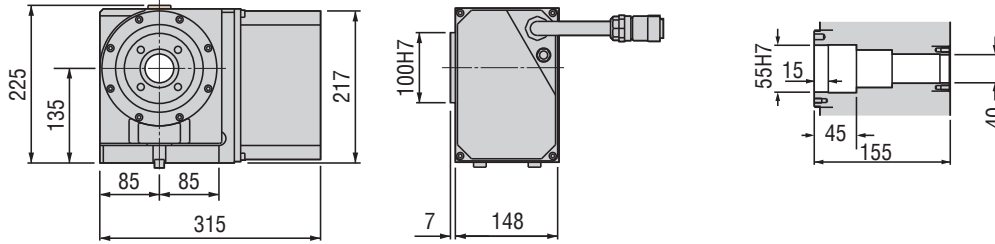

RWE-200 TPC with optional Steel Braided Cable



RWE-160 TPC with 5C Collet



RWE-200 TPC

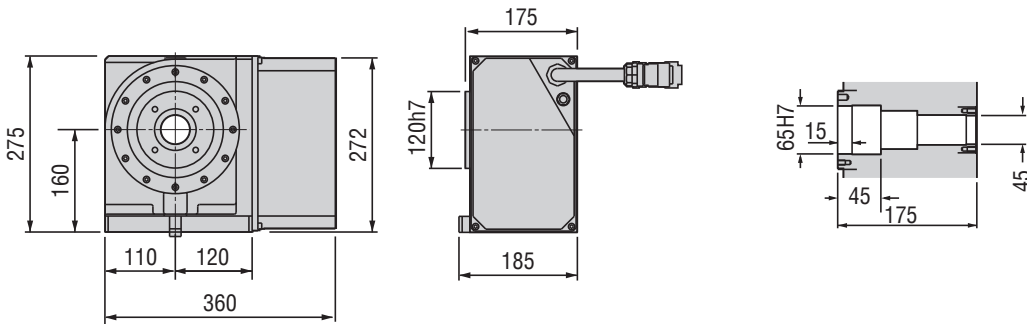

RWE-160 TPC • TS-160 Support Spindle

The rotary table and support spindle are mounted on a baseplate and joined to a specially designed, dual 5C collet trunnion fixture.

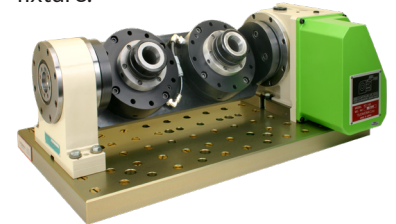

TPC-Jr NC CONTROLLER

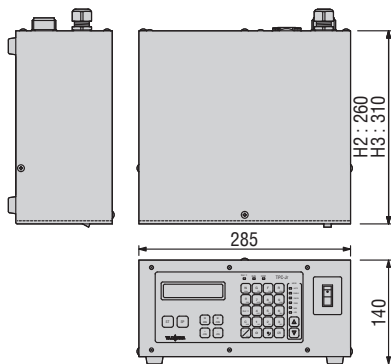

Options & Accessories

TPC NC Controller	p.68
Chucks	p.79
Tailstock	p.81
Support Spindle	p.81
Face Plate	p.83
Encoder / Scale	p.84
Pull Stud Device	p.85
Rotary Joint	p.85
PVC or Steel Cables	p.86

The dimensions above are for tables with a FANUC servo motor. Other motors available (dimensions may increase).

Clamping Block and Bolt

Dimensions = mm

	Q'ty	T-Slot Width	A	B	C	D	E	F	G	H	I	J	K	L	M
RWE-160 TPC	2	14	-	-	-	-	-	-	-	17	8	60	-	23	12
RWE-200 TPC	2	18	-	-	-	-	-	-	-	21	11	65	-	28	16

Note 1: When using a machine with a T-slot pitch other than the above, use suitable clamping blocks and bolts that are available on the market, or order custom-made ones from KOMA (opt.)

Note 2: Clamping blocks are not included in RWE-160 TPC and RWE-200 TPC.

