

LE PARADIS D'ÉVA

Magnum Immobilière S.A.

CONSTRUCTION
DE
19 LOGEMENTS
COLLECTIFS

BATIMENT B
3 allée du maire Steinmetz
MONTIGNY LES METZ



LOGEMENT B102
PLAN DE VENTE

VUE EN PLAN 1/50e



LOGEMENT TYPE 3

B102
T3
63,80M2
TERRASSE:7,83m²

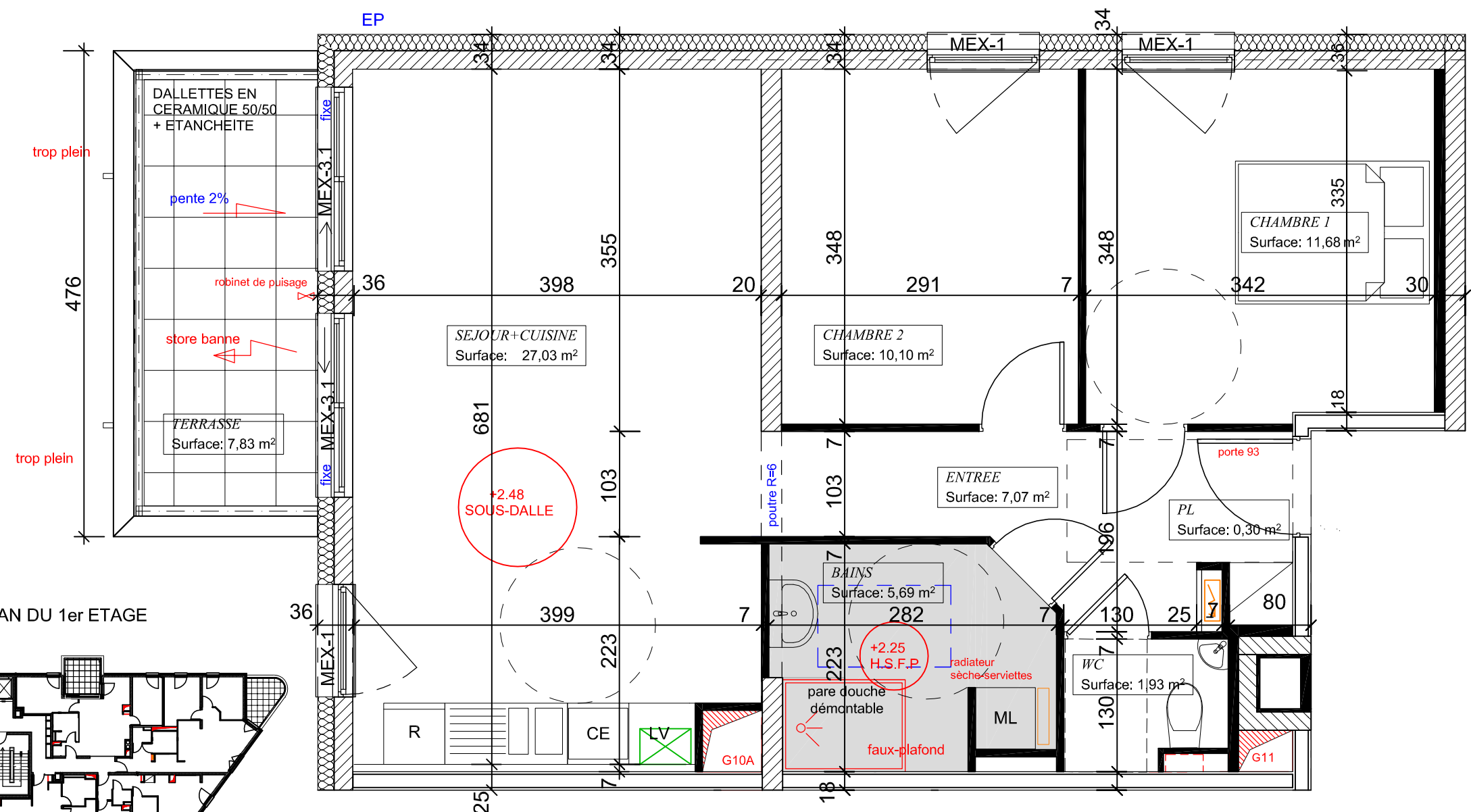

PLAN DU 1er ETAGE

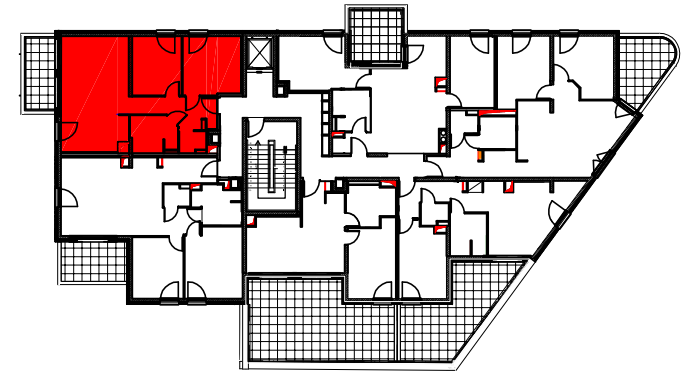

SURFACE HABITABLE	
ENTREE	7.07 m ²
SEJOUR / CUISINE	27.03 m ²
WC	1.93 m ²
SDB	5.69 m ²
CHAMBRE 1	11.68 m ²
CHAMBRE 2	10.10 m ²
PLACARD	0.30 m ²
TOTAL	63.80 m²
TERRASSE	7.83 m ²

LE PARADIS D'EVA

PLAN DE GARAGES ET CAVES

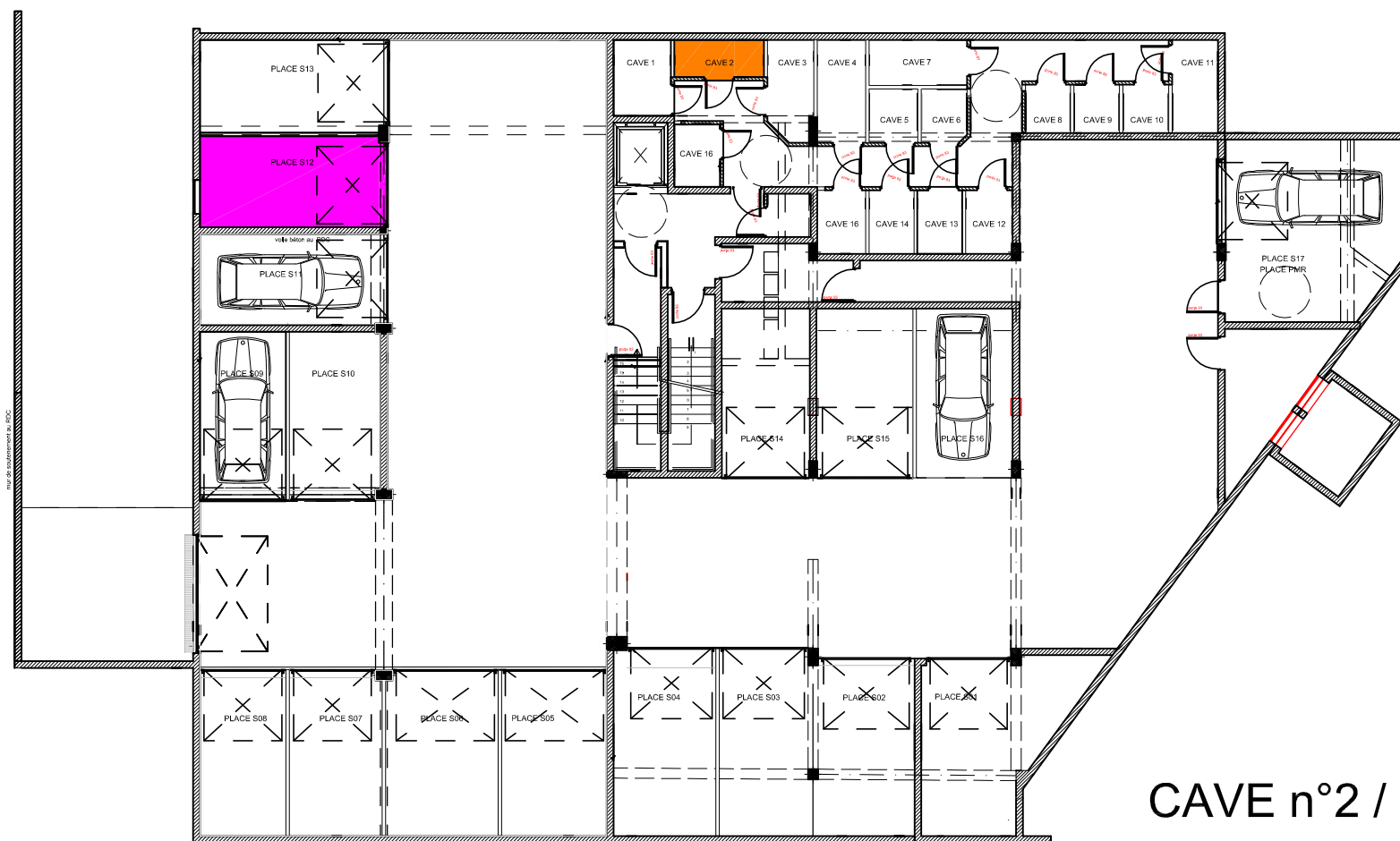

CAVE n°2 / LOT 29

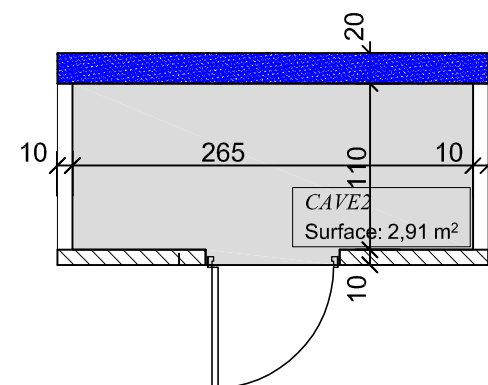

GARAGE n°12 / LOT 54

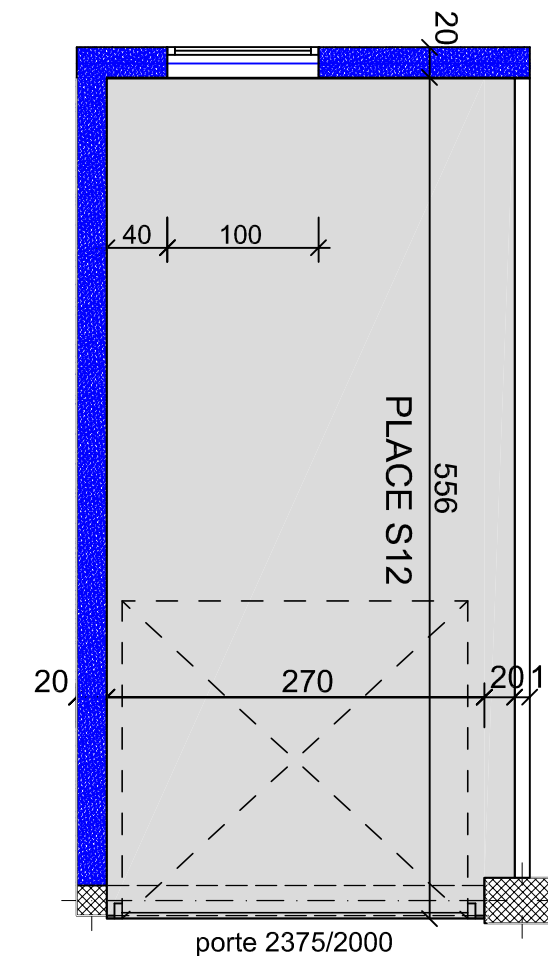

Magnum Immobilière S.A.

CONSTRUCTION
DE
19 LOGEMENTS
COLLECTIFS

BATIMENT B

3 allée du maire Steinmetz
MONTIGNY LES METZ



LOGEMENT B102
PLAN DE VENTE

ANNEXES 1/50e



LISTE DES ANNEXES

GARAGE n°12 / LOT 54	... m²
CAVE n°2 / LOT 29	2,91 m²
PLACE EXTERIEUR : Néant	... m²