

## Rotating Pipe Grab

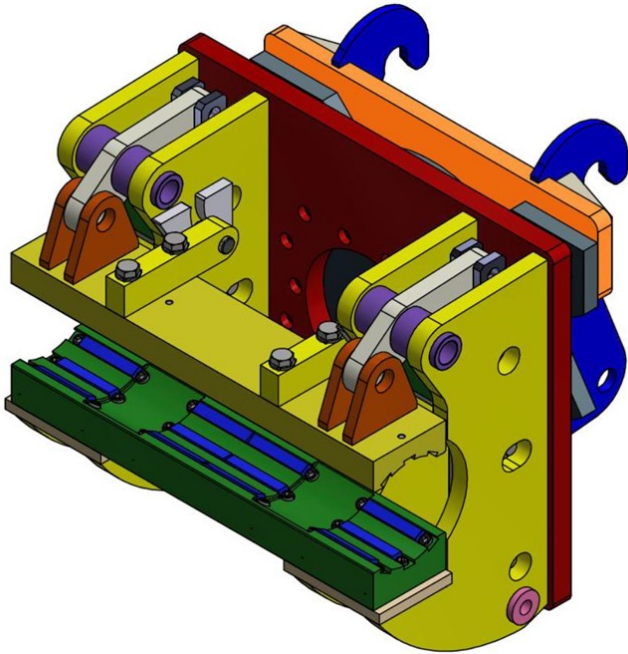

### Equipment Details:

OEM	Mancala	Max Pipe length	3000mm
Model	MCP01	Hitch Arr	Cat QH
Serial Number	MCA50-01-001		
YOM	2014		
Pipe Size	OD 325mm & 220mm		
WLL	250kg		
Threading torque limit	13000Nm		
Weight	1550kg		

The Mancala Group

Ph: +61 (0) 3 8562 9400

Email: [enquiries@mancala.com.au](mailto:enquiries@mancala.com.au)

[www.mancala.com.au](http://www.mancala.com.au)

## Photos:

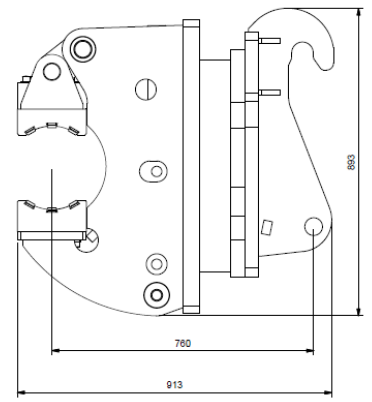
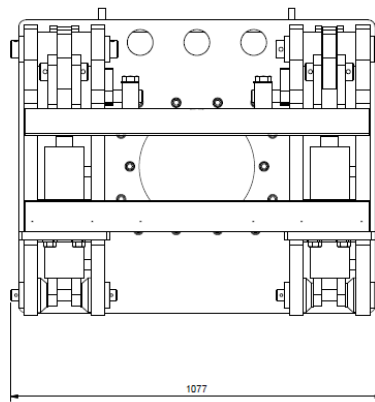

## Additional Info:

Designed for installing paste fill pipes in a underground application full 360 degree rotation, dip, dump and lift controlled by integrated tool carrier. Accumulators installed on clamp gripper to maintain clamping force during installation.

Current quick hitch arrangement is Cat hook style 930H size. Other adapters can be made to suit other OEM machines.

Sale Price	\$70,000.00
Hire Options	Yes
Location	Bendigo Victoria
Contact	Luke Calvert—0459 056 683

### The Mancala Group

- **SAFETY:** Striving to achieve zero harm
- **QUALITY:** Taking pride in what we make and do; on time, on budget and to specification
- **INTEGRITY:** Doing what we say we will do with honesty and respect
- **INNOVATION:** Revolutionising processes and applying technology to achieve better outcomes for all stakeholders
- **PEOPLE:** Recognising people as our greatest asset and encourage personal excellence