

# RSC SAPPHIRE<sup>®</sup>

## ROLLER CHAIN

Performance that's priced right.



1-317-638-6431 1-800 US CHAIN (872-4246)  
[diamondchain.com](http://diamondchain.com)

## TABLE OF CONTENTS

THE "NEW STANDARD"	3	SPECIAL LUBRICATED CHAIN	
		Special Lubricated Chain	8
STANDARD/HEAVY SERIES CHAIN		O-ring Chain	8
Standard Series Chain	4	HOLLOW PIN CHAIN	9
Heavy Series Chain	4	SPECIAL APPLICATION CHAIN	
DOUBLE-PITCH ROLLER CHAIN		Cotton Module Chain	9
Power Transmission Roller Chain	5	Coupling Chain	10
Conveyor Roller Chain	5	Powersports & ATV Chain	10
Standard Diameter Roller	5	Citrus Chain	11
Oversized Diameter Roller	5	Agricultural Chain	11
BRITISH STANDARD ROLLER	6	PITCHES TO FEET CONVERSION TABLE	12
NON-STANDARD ROLLER	6	ORDERING INFORMATION	14
CORROSION/MOISTURE RESISTANT CHAIN			
Nickel Plated Chain	7		
Rust Buster Chain	7		
Stainless Steel Chain	7		

## WHAT WE OFFER OUR CUSTOMERS:

- High standards for import roller chain
- Same day shipments
- Service Centers in California, Texas, and Indiana
- Chain cut to specifications
- Engineering assistance for special requirements
- Full support of Diamond Chain's dedicated sales force

**RSC** SAPPHIRE  
ROLLER CHAIN

# SAPPHIRE ROLLER CHAIN



## SETTING THE “STANDARD” IN TODAY’S IMPORTED CHAIN MARKET

When looking for consistent value-oriented roller chain, look no further than the “New Standard” in today’s imported chain market – Sapphire Roller Chain (RSC brand).

Unlike other imported roller chains that come with no real way to determine their worth, Sapphire roller chain products must meet a stringent set of specifications which determine their quality and consistency. Every shipment of Sapphire roller chain supplied by our overseas partner is carefully screened for its materials and workmanship. Strict attention is given to specifications which cover chain length, heat-treatment uniformity and tensile strength. Each of these standards is uniquely different and far more difficult to achieve than the ANSI dimensional standards most import chains advertise.



For nearly 25 years, Sapphire has been serving the distributor and OEM markets with **consistent, value-added, price sensitive roller chain**; all of which are produced in ISO certified facilities. Sapphire roller chain offers an extensive range of product inventories, national distribution capabilities, and a well trained team of field sales and engineering professionals ready to service your needs.

At Sapphire roller chain, our bottom line is competitive prices and consistent quality products inspected to meet your price-sensitive import chain demands, with the service you expect and deserve.

So, the next time you’re looking for a dependable, price-sensitive roller chain, we invite you to take a closer look at Sapphire roller chain. We believe that a closer look will convince you that when cost with consistency are what matters most, Sapphire roller chain offers you the value-added edge you are looking for.

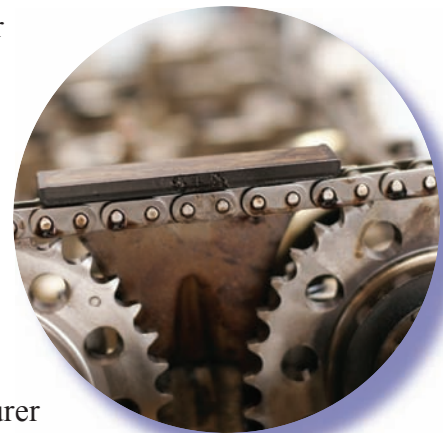

Sapphire roller chain products are imported under the watchful eye of Diamond Chain Company. Diamond Chain is recognized worldwide as a leading manufacturer of high-quality, high-performance roller chain products; manufactured in our U.S. facility since 1890.

# STANDARD/HEAVY SERIES CHAIN

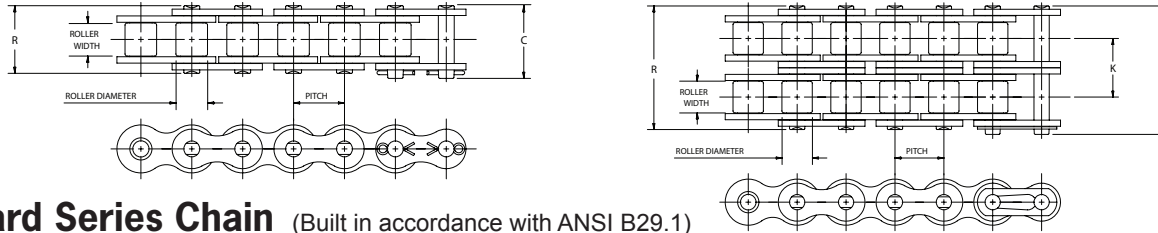

## Standard Series Chain (Built in accordance with ANSI B29.1)

Dimensions in Inches and Pounds

ANSI Number	Pitch Inches	Roller Width	Roller Diameter	Pin Diameter	Link Plate Thickness	C	R	K	Weight per foot	Minimum Tensile Strength
25	1/4	1/8	*.130	.090	.030	0.37	0.34	....	0.084	780
35	3/8	3/16	*.200	.141	.050	0.56	0.50	....	0.210	1760
35-2	3/8	3/16	*.200	.141	.050	0.96	0.90	0.399	0.450	3520
40	1/2	5/16	.312	.156	.060	0.72	0.67	....	0.410	3125
40-2	1/2	5/16	.312	.156	.060	1.29	1.24	0.566	0.800	6250
40-3	1/2	5/16	.312	.156	.060	1.85	1.80	0.566	1.200	9375
41	1/2	1/4	.306	.141	.050	0.65	0.57	....	0.260	1500
50	5/8	3/8	.400	.200	.080	0.89	0.83	....	0.680	4880
50-2	5/8	3/8	.400	.200	.080	1.60	1.55	0.713	1.320	9760
50-3	5/8	3/8	.400	.200	.080	2.31	2.26	0.713	1.980	14640
60	3/4	1/2	.469	.234	.094	1.11	1.04	....	0.990	7030
60-2	3/4	1/2	.469	.234	.094	2.01	1.94	0.897	1.950	14060
60-3	3/4	1/2	.469	.234	.094	2.91	2.84	0.897	2.880	21090
80	1	5/8	.625	.312	.125	1.44	1.32	....	1.730	12500
80-2	1	5/8	.625	.312	.125	2.59	2.47	1.153	3.370	25000
100	1 1/4	3/4	.750	.375	.156	1.73	1.61	....	2.510	19530
100-2	1 1/4	3/4	.750	.375	.156	3.14	3.02	1.408	4.910	39060
120	1 1/2	1	.875	.437	.187	2.14	2.00	....	3.690	28125
120-2	1 1/2	1	.875	.437	.187	3.93	3.79	1.789	7.350	56250
140	1 3/4	1	1.000	.500	.219	2.31	2.14	....	5.000	38280
140-2	1 3/4	1	1.000	.500	.219	4.24	4.07	1.924	9.650	76560
160	2	1 1/4	1.125	.562	.250	2.73	2.54	....	6.530	50000
160-2	2	1 1/4	1.125	.562	.250	5.04	4.85	2.305	12.830	100000
180	2 1/4	1 13/32	1.406	.687	.281	3.15	2.88	....	9.060	63280
180-2	2 1/4	1 13/32	1.406	0.687	0.281	5.87	5.51	2.592	17.510	126,677
200	2 1/2	1 1/2	1.562	.781	.312	3.44	3.12	....	10.650	78125
200-2	2 1/2	1 1/2	1.562	.781	.312	6.26	5.94	2.817	21.500	156250
240	3	1 7/8	1.875	.937	.375	4.06	3.72	....	16.400	112500

\*Chains are rollerless -- dimension shown is bushing diameter.

## Heavy Series Chain<sup>†</sup> (Built in accordance with ANSI B29.1)

Dimensions in Inches and Pounds

ANSI Number	Pitch Inches	Roller Width	Roller Diameter	Pin Diameter	Link Plate Thickness	C	R	K	Weight per foot	Minimum Tensile Strength
50H	5/8	3/8	0.400	0.200	0.094	0.93	0.86	....	0.850	5,886
60H	3/4	1/2	.469	.234	.125	1.24	1.17	....	1.18	7030
80H	1	5/8	.625	.312	.156	1.57	1.45	....	2.02	12500
100H	1 1/4	3/4	.750	.375	.187	1.86	1.74	....	2.82	19530
120H	1 1/2	1	.875	.437	.219	2.27	2.13	....	4.08	28125
140H	1 3/4	1	1.000	.500	.250	2.44	2.28	....	5.40	38280
160H	2	1 1/4	1.125	.562	.281	2.86	2.68	....	7.03	50000

<sup>†</sup>Heavy Series chains are not necessarily stronger than Standard Series chains, but thicker link plate material provides an increase in fatigue resistance for those drives subjected to heavy shock loads.

# DOUBLE-PITCH ROLLER CHAIN

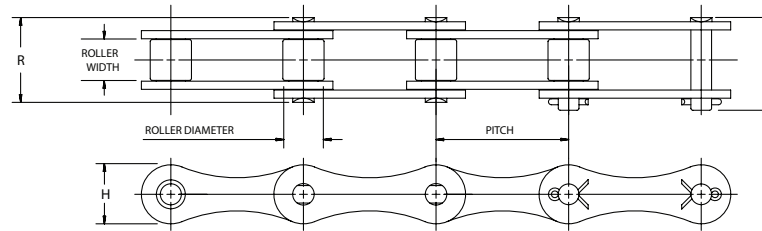

## Power Transmission Roller Chain (Built in accordance with ANSI B29.1)

Dimensions in Inches and Pounds

ANSI Number	Pitch Inches	Roller Width	Roller Diameter	Pin Diameter	Link Plate Thickness	C	R	Weight per foot	Minimum Tensile Strength
2040	1	5/16	.312	.156	.060	.76	.68	.28	3125
2050	1 1/4	3/8	.400	.200	.080	.92	.84	.52	4880
2060	1 1/2	1/2	.469	.234	.094	1.11	1.05	.72	7030

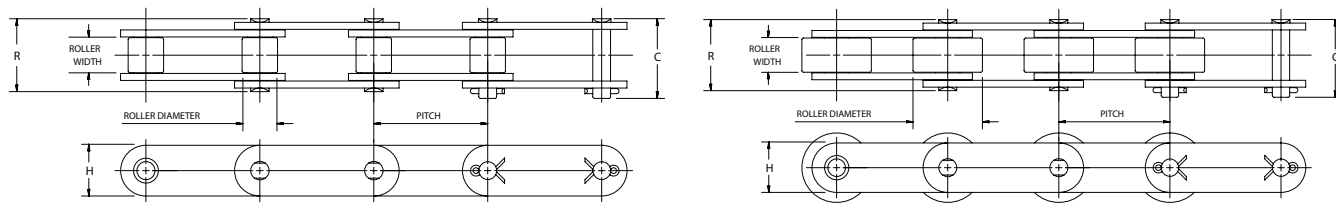

## Conveyor Roller Chain (Built in accordance with ANSI B29.1)

### Standard Diameter Roller

Dimensions in Inches and Pounds

ANSI Number	Pitch Inches	Roller Width	Roller Diameter	Pin Diameter	Link Plate Thickness	C	R	Weight per foot	Minimum Tensile Strength
C2040	1	5/16	.312	.156	.060	.76	.68	.34	3125
C2050	1 1/4	3/8	.400	.200	.080	.92	.84	.58	4880
C2060H	1 1/2	1/2	.469	.234	.125	1.25	1.18	1.05	7030
C2080H	2	5/8	.625	.312	.156	1.57	1.45	1.40	12500

### Oversized Diameter Roller

Dimensions in Inches and Pounds

ANSI Number	Pitch Inches	Roller Width	Roller Diameter	Pin Diameter	Link Plate Thickness	C	R	Weight per foot	Minimum Tensile Strength
C2042	1	5/16	.625	.156	.060	.76	.68	.50	3125
C2052	1 1/4	3/8	.750	.200	.080	.92	.84	.81	4880
C2062H	1 1/2	1/2	.875	.234	.125	1.25	1.18	1.42	7030

# BRITISH STANDARD ROLLER CHAIN

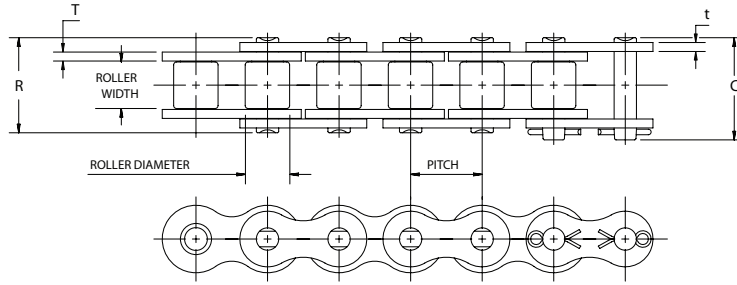

Dimensions in Inches and Pounds

ISO Number	Pitch Inches	Roller Width	Roller Diameter	Pin Diameter	T	t	C	R	K	Weight per foot	Minimum Tensile Strength
*06B-1	3/8	.225	.250	.129	.050	.039	.661	.531	....	.30	2000
*06B-2	3/8	.225	.250	.129	.050	.039	1.067	.937	.403	.54	3800
08B-1	1/2	.305	.335	.175	.059	.059	.823	.669	....	.50	4000
08B-2	1/2	.305	.335	.175	.059	.059	1.374	1.220	.548	.95	7000
10B-1	5/8	.380	.400	.200	.059	.059	.933	.772	....	.64	5000
10B-2	5/8	.380	.400	.200	.059	.059	1.587	1.425	.653	1.26	1000
12B-1	3/4	.460	.475	.225	.071	.071	1.075	.894	....	.80	6500
12B-2	3/4	.460	.475	.225	.071	.071	1.843	1.661	.766	1.57	13000
16B-1	1	.670	.625	.326	.157	.126	1.531	1.319	....	1.83	9500
16B-2	1	.670	.625	.326	.157	.126	2.890	2.677	1.260	3.61	19000
20B-1	1 1/4	.770	.750	.401	.177	.138	1.941	1.701	....	2.61	14500
20B-2	1 1/4	.770	.750	.401	.177	.138	3.378	3.138	1.435	5.15	29000
24B-1	1 1/2	1.000	1.000	.576	.236	.204	2.362	2.102	....	4.75	22000
24B-2	1 1/2	1.000	1.000	.576	.236	.204	4.268	4.008	1.904	9.39	44000
28B-1	1 3/4	1.220	1.100	.626	.295	.248	2.850	2.560	....	6.35	29000
32B-1	2	1.220	1.150	.701	.276	.248	2.960	2.650	....	6.89	38000

\*Straight sidebar chain.

# NON-STANDARD ROLLER CHAIN

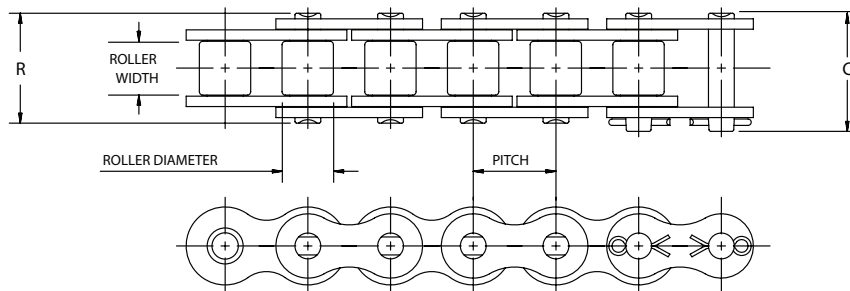

Dimensions in Inches and Pounds

Chain	Pitch Inches	Roller Width	Roller Diameter	Pin Diameter	Link Plate Thickness	C	R	Weight per foot	Minimum Tensile Strength
65 x 1/8	1/2	1/8	*.306	.141	.040	.46	.42	.180	2050

\*Chains are rollerless -- dimension shown is bushing diameter.

# CORROSION/MOISTURE RESISTANT CHAIN

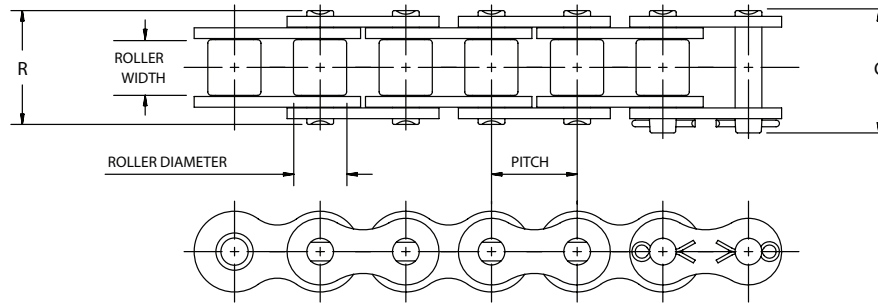

## Nickel-Plated Chain

Dimensions in Inches and Pounds

Sapphire Number	Pitch Inches	Roller Width	Roller Diameter	Pin Diameter	Link Plate Thickness	C	R	K	Weight per foot	Minimum Tensile Strength
25NP	1/4	1/4	*.130	0.090	0.030	0.37	0.34	....	0.084	780
35NP	3/8	1/4	*.200	0.141	0.050	0.56	0.5	....	0.220	1760
40NP	1/2	5/16	0.312	0.156	0.060	0.72	0.67	....	0.420	3125
40-2NP	1/2	5/16	0.342	0.156	0.060	1.29	1.24	0.566	0.800	6250
41NP	1/2	1/4	0.306	0.141	0.050	0.65	0.57	....	0.260	1500
50NP	5/8	3/8	0.400	0.200	0.080	0.89	0.83	....	0.680	4880
50-2NP	5/8	3/8	0.400	0.200	0.080	1.60	1.55	0.713	1.320	9760
60NP	3/4	1/2	0.469	0.234	0.094	1.11	1.04	....	0.990	7030
80NP	1	5/8	0.625	0.312	0.125	1.44	1.32	....	1.725	12500

\*Chains are rollerless -- dimension shown is bushing diameter.

## Stainless Steel Chain

Dimensions in Inches and Pounds

Sapphire Number	Pitch Inches	Roller Width	Roller Diameter	Pin Diameter	Link Plate Thickness	C	R	K	Weight per foot	Minimum Tensile Strength
25SS	1/4	1/4	*.130	0.090	0.030	0.37	0.34	....	0.084	540
35SS	3/8	1/4	*.200	0.141	0.050	0.56	0.5	....	0.225	1256
40SS	1/2	5/16	0.312	0.156	0.060	0.72	0.67	....	0.420	2203
40-2SS	1/2	5/16	0.342	0.156	0.060	1.29	1.24	0.566	0.826	4400
50SS	5/8	3/8	0.400	0.200	0.080	0.89	0.83	....	0.680	3525
50-2SS	5/8	3/8	0.400	0.200	0.080	1.60	1.55	0.713	1.400	7050
60SS	3/4	1/2	0.469	0.234	0.094	1.11	1.04	....	0.990	5070
60-2SS	3/4	1/2	0.469	0.234	0.094	2.01	1.94	0.897	1.936	10100
80SS	1	5/8	0.625	0.312	0.125	1.44	1.32	....	1.725	9035

\*Chains are rollerless -- dimension shown is bushing diameter.

## Rust-Buster Chain

Dimensions in Inches and Pounds

Sapphire Number	Pitch Inches	Roller Width	Roller Diameter	Pin Diameter	Link Plate Thickness	C	R	Weight per foot	Minimum Tensile Strength
40RB	1/2	5/16	0.312	0.156	0.060	0.72	0.67	0.420	2190
50RB	5/8	3/8	0.400	0.200	0.080	0.89	0.83	0.680	3420
60RB	3/4	1/2	0.469	0.234	0.094	1.11	1.04	0.990	4950
80RB	1	5/8	0.625	0.312	0.125	1.44	1.32	1.725	8750

# SPECIAL LUBRICATED CHAIN

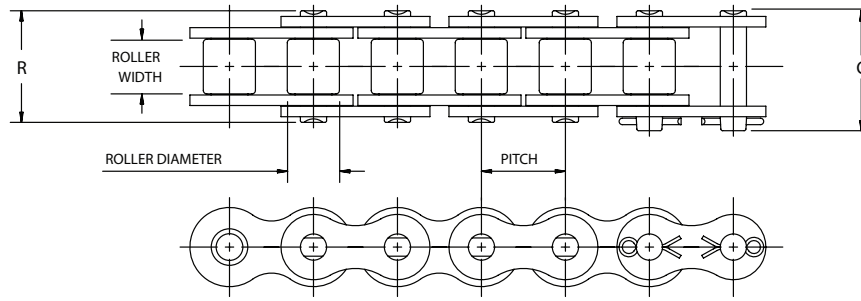

## Self Lubricated Chain

Dimensions in Inches and Pounds

Sapphire Number	Pitch Inches	Roller Width	Roller Diameter	Pin Diameter	Link Plate Thickness	C	R	Weight per foot	Minimum Tensile Strength
40SL	1/2	5/16	0.312	0.156	0.060	0.72	0.67	0.420	3125
50SL	5/8	3/8	0.400	0.200	0.080	0.89	0.83	0.680	4880
60SL	3/4	1/2	0.469	0.234	0.094	1.11	1.04	0.990	7030
80SL	1	5/8	0.625	0.312	0.125	1.44	1.32	1.725	12500

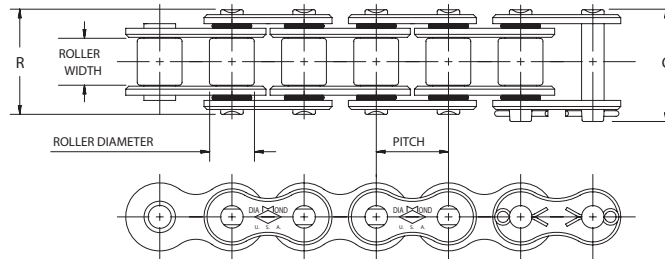

## O-Ring Chain

Dimensions in Inches and Pounds

Sapphire Number	Pitch Inches	Roller Width	Roller Diameter	Pin Diameter	Link Plate Thickness	C	R	Weight per foot	Minimum Tensile Strength
40SXLO	1/2	5/16	0.312	0.156	0.060	0.86	0.78	0.420	3125
50SXLO	5/8	3/8	0.400	0.200	0.080	1.01	0.93	0.680	4880
60SXLO	3/4	1/2	0.469	0.234	0.094	1.24	1.13	0.990	7030
80SXLO	1	5/8	0.625	0.312	0.125	1.69	0.16	1.725	12500

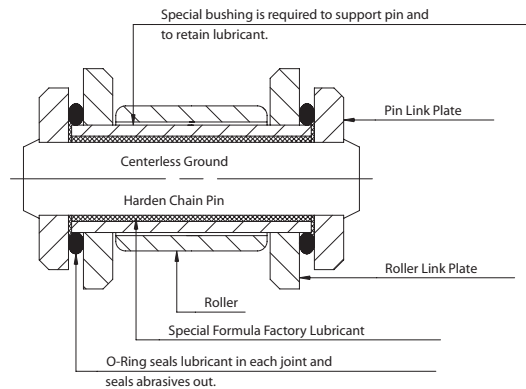



# HOLLOW PIN CHAIN

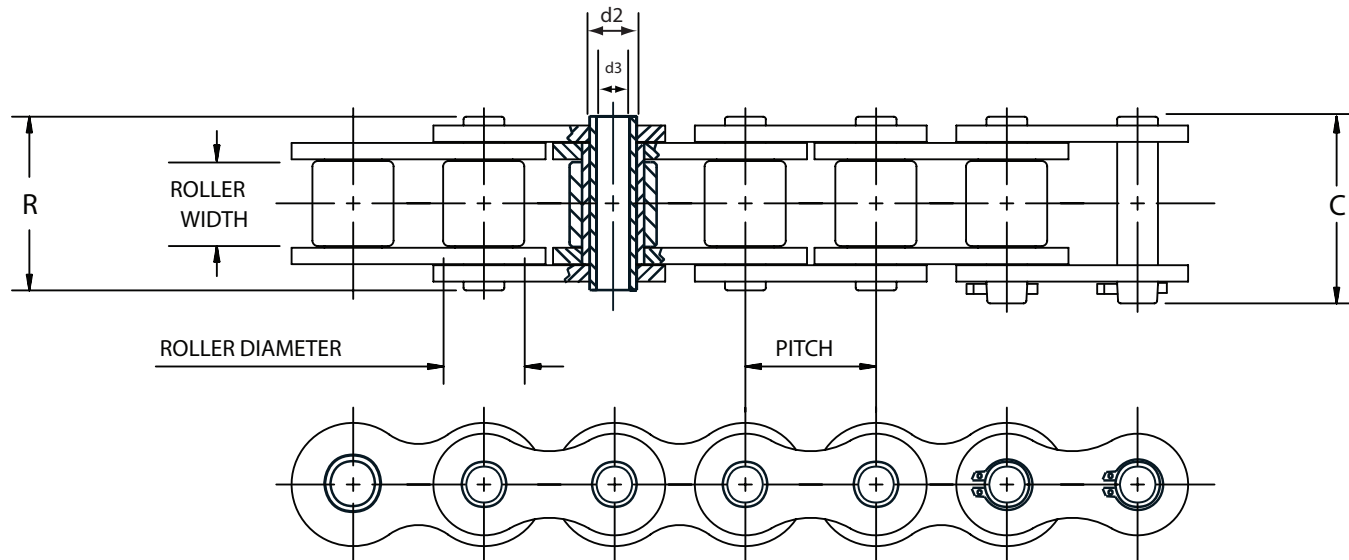

Dimensions in Inches and Pounds

Sapphire Number	Pitch Inches	Roller Width	Roller Diameter	Pin Outer Diameter d2	Pin Inner Diameter d3	Link Plate Height H	Link Plate Thickness	C	R	Weight per foot	Minimum Tensile Strength
40HP	0.500	0.309	0.312	0.222	0.157	0.472	0.059	0.693	0.650	0.390	2205
50HP	0.625	0.370	0.400	0.277	0.202	0.594	0.079	0.862	0.815	0.637	4079
60HP	0.750	0.495	0.469	0.327	0.236	0.709	0.094	1.055	1.016	0.939	5732
80HP	1.000	0.620	0.625	0.449	0.317	0.945	0.126	1.331	1.280	1.697	11023
C2040HP	1.000	.0309	0.312	0.222	0.157	0.472	0.059	0.693	0.650	0.305	2205
C2050HP	1.250	.0370	0.400	0.284	0.202	0.591	0.079	0.862	0.815	0.500	4079
C2060HP	1 1/2	0.495	0.469	0.327	0.236	0.669	0.094	1.055	1.015	0.93	5732
C2062H HP	1 1/2	0.495	0.875	0.327	0.236	0.669	0.126	1.055	1.015	1.30	5732
C2080HP	2	0.620	0.625	0.449	0.370	0.945	0.126	1.331	1.280	1.21	11023
C2082H HP	2	0.620	1.125	0.449	0.317	0.945	0.156	1.331	1.280	1.58	11023

# SPECIAL APPLICATION CHAIN

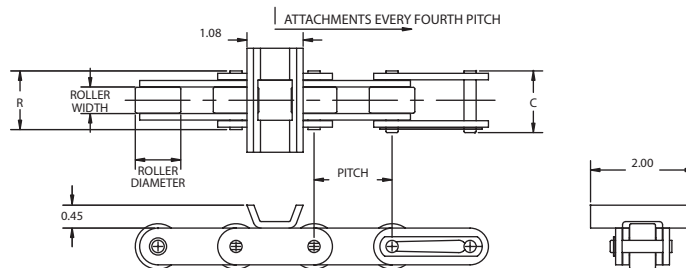

## Cotton Module Roller Chain

Dimensions in Inches and Pounds

Diamond AG Number	Pitch	Roller Width	Roller Diameter	Pin Diameter	C	R	Link Plate Thickness	Minimum Tensile Strength
C2062H CM	1 1/2	1/2	.875	.234	1.25	1.18	.125	7030

# SPECIAL APPLICATION CHAIN

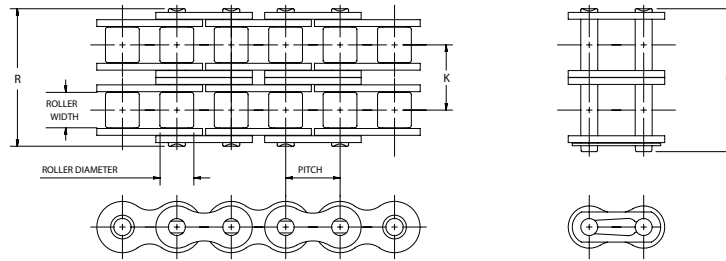

## Coupling Chain

Dimensions in Inches and Pounds

Sapphire Number	Pitch Inches	Roller Width	Roller Diameter	C	R	K	Length Pitches	Weight Per Chain
D4012	1/2	.312	.312	1.297	1.24	.566	12	.41
D4016	1/2	.312	.312	1.297	1.24	.566	16	.55
D5016	5/8	.375	.400	1.592	1.55	.713	16	1.12
D5018	5/8	.375	.400	1.592	1.55	.713	18	1.26
D6018	3/4	.500	.469	1.980	1.94	.897	18	2.16
D6020	3/4	.500	.469	1.980	1.94	.897	20	2.40
D6022	3/4	.500	.469	1.980	1.94	.897	22	2.64
D8018	1	.625	.625	2.567	2.47	1.153	18	5.00
D8020	1	.625	.625	2.567	2.47	1.153	20	5.56
D10018	1 1/4	.750	.750	3.162	3.02	1.408	18	9.24
D10020	1 1/4	.750	.750	3.162	3.02	1.408	20	10.30
D12018	1 1/2	1.000	.875	3.977	3.79	1.789	18	16.20
D12022	1 1/2	1.000	.875	3.977	3.79	1.789	22	19.80

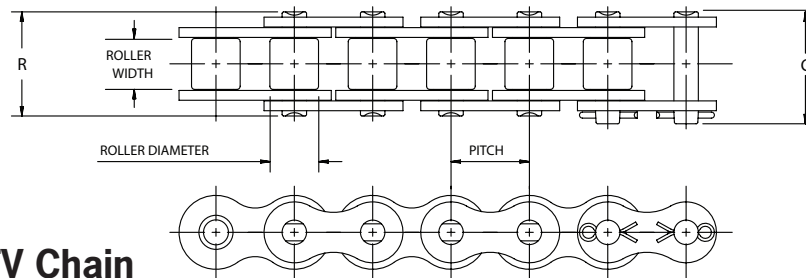

## Powersports & ATV Chain

Dimensions in Inches and Pounds

Sapphire Number	Pitch Inches	Roller Width	Roller Diameter	Pin Diameter	Link Plate Thickness	C	R	Weight per foot	Average Tensile Strength
219H	0.306	0.197	0.181	0.118	0.047	....	0.472	0.200	1720
219H BP	0.306	0.197	0.181	0.118	0.047	....	0.472	0.200	1720
420	1/2	1/4	0.306	0.156	0.060	0.654	0.583	0.270	4070
428	1/2	5/16	0.335	0.174	0.060	0.713	0.661	0.448	4200
428H	1/2	5/16	0.335	0.174	0.070	0.766	0.744	0.536	4200
520	5/8	1/4	0.400	0.200	0.080	0.770	0.710	0.631	6600
520H	5/8	1/4	0.400	0.200	0.094	0.800	0.740	0.817	6600
530	5/8	5/8	0.400	0.200	0.080	0.890	0.830	0.711	6600
530H	5/8	5/8	0.400	0.200	0.094	0.920	0.860	0.897	6600

# SPECIAL APPLICATION CHAIN

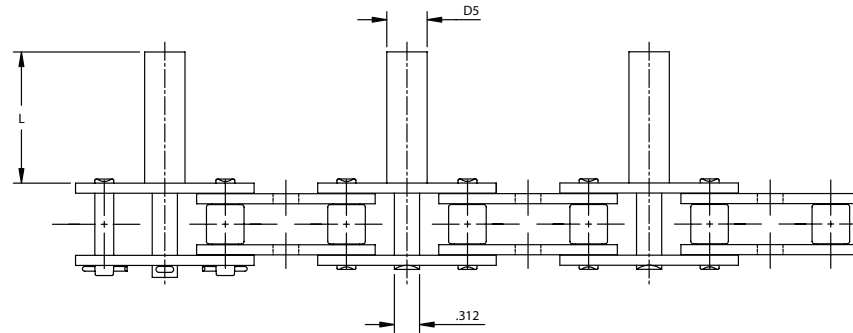

## Citrus Chain

Dimensions in Inches and Pounds

Type	D5	"L"
1	1/2	1.625
2	9/16	1.625

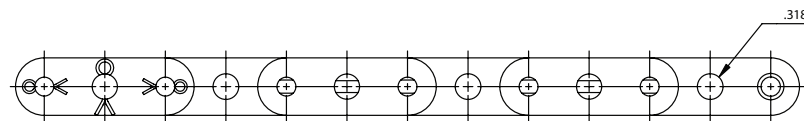

Sapphire Number	Pitch Inches	Roller Width	Roller Diameter	Pin Diameter	Link Plate Thickness	C	R	Weight Per Foot*	Minimum Tensile Strength
C2060H C	1 1/2	0.495	0.469	0.234	0.125	1.25	1.18	1.05	7030
C2060HSS C	1 1/2	0.495	0.469	0.234	0.125	1.25	1.18	1.03	5730

\*Approximate - weight will vary depending upon D5 pin required

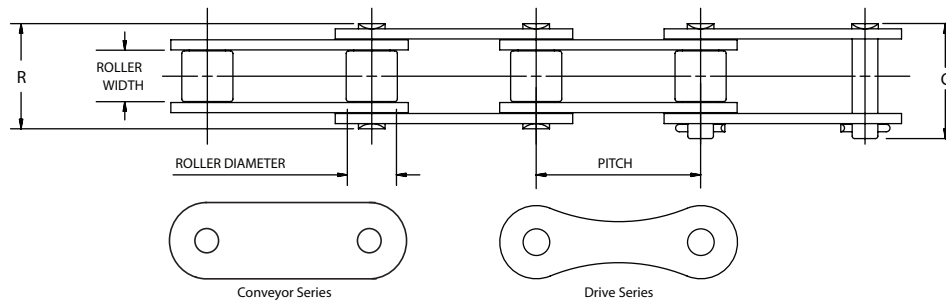

## Agricultural Chain

Dimensions in Inches and Pounds

Sapphire Number	Pitch	Roller Width	Roller Diameter	Pin Diameter	Link Plate Thickness	C	R	Weight Per Foot	Average Tensile Strength
Conveyor Series									
CA550	1.63	51/64	.656	.283	.105	1 9/16	1 3/8	1.30	12125
CA555	1.63	1/2	.656	.283	.125	1 1/4	1 3/16	1.21	13228
CA557	1.63	51/64	.700	.315	.125	1 19/32	1 15/32	1.72	16535
CA620	1.654	63/64	.696	.283	.125	1 27/32	1 41/64	1.57	13228
C2060H	1.50	1/2	.469	.235	.125	1 1/4	1 3/16	1.05	9700
Drive Series									
A550	1.63	51/64	.656	.283	.105	1 9/16	1 3/8	1.10	12125
A620	1.654	63/64	.696	.283	.125	1 27/32	1 41/64	1.38	13228

## Other Special Application Chains

Sapphire provides many unique Special Application Chains upon request; if you don't see what you're looking for please contact an Inside Sales person at 1-800-872-4246 to request a quote for your specific need.

# CHAIN LENGTH IN PITCHES TO FEET CONVERSION TABLE

Chain Pitch—Inches													
No. of Pitches	¼	⅜	½	⅝	¾	1	1¼	1½	1¾	2	2¼	2½	3
Chain Length—Feet													
1	0.02	0.03	0.04	0.05	0.06	0.08	0.10	0.13	0.15	0.17	0.19	0.21	0.25
2	0.04	0.06	0.08	0.10	0.13	0.17	0.21	0.25	0.29	0.33	0.38	0.42	0.50
3	0.06	0.09	0.13	0.16	0.19	0.25	0.31	0.38	0.44	0.50	0.56	0.63	0.75
4	0.08	0.13	0.17	0.21	0.25	0.33	0.42	0.50	0.58	0.67	0.75	0.83	1.00
5	0.10	0.16	0.21	0.26	0.31	0.42	0.52	0.63	0.73	0.83	0.94	1.04	1.25
6	0.13	0.19	0.25	0.31	0.38	0.50	0.63	0.75	0.88	1.00	1.13	1.25	1.50
7	0.15	0.22	0.29	0.36	0.44	0.58	0.73	0.88	1.02	1.17	1.31	1.46	1.75
8	0.17	0.25	0.33	0.42	0.50	0.67	0.83	1.00	1.17	1.33	1.50	1.67	2.00
9	0.19	0.28	0.38	0.47	0.56	0.75	0.94	1.13	1.31	1.50	1.69	1.88	2.25
10	0.21	0.31	0.42	0.52	0.63	0.83	1.04	1.25	1.46	1.67	1.88	2.08	2.50
11	0.23	0.34	0.46	0.57	0.69	0.92	1.15	1.38	1.60	1.83	2.06	2.29	2.75
12	0.25	0.38	0.50	0.63	0.75	1.00	1.25	1.50	1.75	2.00	2.25	2.50	3.00
13	0.27	0.41	0.54	0.68	0.81	1.08	1.35	1.63	1.90	2.17	2.44	2.71	3.25
14	0.29	0.44	0.58	0.73	0.88	1.17	1.46	1.75	2.04	2.33	2.63	2.92	3.50
15	0.31	0.47	0.63	0.78	0.94	1.25	1.56	1.88	2.19	2.50	2.81	3.13	3.75
16	0.33	0.50	0.67	0.83	1.00	1.33	1.67	2.00	2.33	2.67	3.00	3.33	4.00
17	0.35	0.53	0.71	0.89	1.06	1.42	1.77	2.13	2.48	2.83	3.19	3.54	4.25
18	0.38	0.56	0.75	0.94	1.13	1.50	1.88	2.25	2.63	3.00	3.38	3.75	4.50
19	0.40	0.59	0.79	0.99	1.19	1.58	1.98	2.38	2.77	3.17	3.56	3.96	4.75
20	0.42	0.63	0.83	1.04	1.25	1.67	2.08	2.50	2.92	3.33	3.75	4.17	5.00
21	0.44	0.66	0.88	1.09	1.31	1.75	2.19	2.63	3.06	3.50	3.94	4.38	5.25
22	0.46	0.69	0.92	1.15	1.38	1.83	2.29	2.75	3.21	3.67	4.13	4.58	5.50
23	0.48	0.72	0.96	1.20	1.44	1.92	2.40	2.88	3.35	3.83	4.31	4.79	5.75
24	0.50	0.75	1.00	1.25	1.50	2.00	2.50	3.00	3.50	4.00	4.50	5.00	6.00
25	0.52	0.78	1.04	1.30	1.56	2.08	2.60	3.13	3.65	4.17	4.69	5.21	6.25
26	0.54	0.81	1.08	1.35	1.63	2.17	2.71	3.25	3.79	4.33	4.88	5.42	6.50
27	0.56	0.84	1.13	1.41	1.69	2.25	2.81	3.38	3.94	4.50	5.06	5.63	6.75
28	0.58	0.88	1.17	1.46	1.75	2.33	2.92	3.50	4.08	4.67	5.25	5.83	7.00
29	0.60	0.91	1.21	1.51	1.81	2.42	3.02	3.63	4.23	4.83	5.44	6.04	7.25
30	0.63	0.94	1.25	1.56	1.88	2.50	3.13	3.75	4.38	5.00	5.63	6.25	7.50
31	0.65	0.97	1.29	1.61	1.94	2.58	3.23	3.88	4.52	5.17	5.81	6.46	7.75
32	0.67	1.00	1.33	1.67	2.00	2.67	3.33	4.00	4.67	5.33	6.00	6.67	8.00
33	0.69	1.03	1.38	1.72	2.06	2.75	3.44	4.13	4.81	5.50	6.19	6.88	8.25
34	0.71	1.06	1.42	1.77	2.13	2.83	3.54	4.25	4.96	5.67	6.38	7.08	8.50
35	0.73	1.09	1.46	1.82	2.19	2.92	3.65	4.38	5.10	5.83	6.56	7.29	8.75
36	0.75	1.13	1.50	1.88	2.25	3.00	3.75	4.50	5.25	6.00	6.75	7.50	9.00
37	0.77	1.16	1.54	1.93	2.31	3.08	3.85	4.63	5.40	6.17	6.94	7.71	9.25
38	0.79	1.19	1.58	1.98	2.38	3.17	3.96	4.75	5.54	6.33	7.13	7.92	9.50
39	0.81	1.22	1.63	2.03	2.44	3.25	4.06	4.88	5.69	6.50	7.31	8.13	9.75
40	0.83	1.25	1.67	2.08	2.50	3.33	4.17	5.00	5.83	6.67	7.50	8.33	10.00
41	0.85	1.28	1.71	2.14	2.56	3.42	4.27	5.13	5.98	6.83	7.69	8.54	10.25
42	0.88	1.31	1.75	2.19	2.63	3.50	4.38	5.25	6.13	7.00	7.88	8.75	10.50
43	0.90	1.34	1.79	2.24	2.69	3.58	4.48	5.38	6.27	7.17	8.06	8.96	10.75
44	0.92	1.38	1.83	2.29	2.75	3.67	4.58	5.50	6.42	7.33	8.25	9.17	11.00
45	0.94	1.41	1.88	2.34	2.81	3.75	4.69	5.63	6.56	7.50	8.44	9.38	11.25
46	0.96	1.44	1.92	2.40	2.88	3.83	4.79	5.75	6.71	7.67	8.63	9.58	11.50
47	0.98	1.47	1.96	2.45	2.94	3.92	4.90	5.88	6.85	7.83	8.81	9.79	11.75
48	1.00	1.50	2.00	2.50	3.00	4.00	5.00	6.00	7.00	8.00	9.00	10.00	12.00
49	1.02	1.53	2.04	2.55	3.06	4.08	5.10	6.13	7.15	8.17	9.19	10.21	12.25
50	1.04	1.56	2.08	2.60	3.13	4.17	5.21	6.25	7.29	8.33	9.38	10.42	12.50

# CHAIN LENGTH IN PITCHES TO FEET CONVERSION TABLE

Chain Pitch—Inches													
No. of Pitches	¼	⅜	½	⅝	¾	1	1¼	1½	1¾	2	2¼	2½	3
Chain Length—Feet													
51	1.06	1.59	2.13	2.66	3.19	4.25	5.31	6.38	7.44	8.50	9.56	10.63	12.75
52	1.08	1.63	2.17	2.71	3.25	4.33	5.42	6.50	7.58	8.67	9.75	10.83	13.00
53	1.10	1.66	2.21	2.76	3.31	4.42	5.52	6.63	7.73	8.83	9.94	11.04	13.25
54	1.13	1.69	2.25	2.81	3.38	4.50	5.63	6.75	7.88	9.00	10.13	11.25	13.50
55	1.15	1.72	2.29	2.86	3.44	4.58	5.73	6.88	8.02	9.17	10.31	11.46	13.75
56	1.17	1.75	2.33	2.92	3.50	4.67	5.83	7.00	8.17	9.33	10.50	11.67	14.00
57	1.19	1.78	2.38	2.97	3.56	4.75	5.94	7.13	8.31	9.50	10.69	11.88	14.25
58	1.21	1.81	2.42	3.02	3.63	4.83	6.04	7.25	8.46	9.67	10.88	12.08	14.50
59	1.23	1.84	2.46	3.07	3.69	4.92	6.15	7.38	8.60	9.83	11.06	12.29	14.75
60	1.25	1.88	2.50	3.13	3.75	5.00	6.25	7.50	8.75	10.00	11.25	12.50	15.00
61	1.27	1.91	2.54	3.18	3.81	5.08	6.35	7.63	8.90	10.17	11.44	12.71	15.25
62	1.29	1.94	2.58	3.23	3.88	5.17	6.46	7.75	9.04	10.33	11.63	12.92	15.50
63	1.31	1.97	2.63	3.28	3.94	5.25	6.56	7.88	9.19	10.50	11.81	13.13	15.75
64	1.33	2.00	2.67	3.33	4.00	5.33	6.67	8.00	9.33	10.67	12.00	13.33	16.00
65	1.35	2.03	2.71	3.39	4.06	5.42	6.77	8.13	9.48	10.83	12.19	13.54	16.25
66	1.38	2.06	2.75	3.44	4.13	5.50	6.88	8.25	9.63	11.00	12.38	13.75	16.50
67	1.40	2.09	2.79	3.49	4.19	5.58	6.98	8.38	9.77	11.17	12.56	13.96	16.75
68	1.42	2.13	2.83	3.54	4.25	5.67	7.08	8.50	9.92	11.33	12.75	14.17	17.00
69	1.44	2.16	2.88	3.59	4.31	5.75	7.19	8.63	10.06	11.50	12.94	14.38	17.25
70	1.46	2.19	2.92	3.65	4.38	5.83	7.29	8.75	10.21	11.67	13.13	14.58	17.50
71	1.48	2.22	2.96	3.70	4.44	5.92	7.40	8.88	10.35	11.83	13.31	14.79	17.75
72	1.50	2.25	3.00	3.75	4.50	6.00	7.50	9.00	10.50	12.00	13.50	15.00	18.00
73	1.52	2.28	3.04	3.80	4.56	6.08	7.60	9.13	10.65	12.17	13.69	15.21	18.25
74	1.54	2.31	3.08	3.85	4.63	6.17	7.71	9.25	10.79	12.33	13.88	15.42	18.50
75	1.56	2.34	3.13	3.91	4.69	6.25	7.81	9.38	10.94	12.50	14.06	15.63	18.75
76	1.58	2.38	3.17	3.96	4.75	6.33	7.92	9.50	11.08	12.67	14.25	15.83	19.00
77	1.60	2.41	3.21	4.01	4.81	6.42	8.02	9.63	11.23	12.83	14.44	16.04	19.25
78	1.63	2.44	3.25	4.06	4.88	6.50	8.13	9.75	11.38	13.00	14.63	16.25	19.50
79	1.65	2.47	3.29	4.11	4.94	6.58	8.23	9.88	11.52	13.17	14.81	16.46	19.75
80	1.67	2.50	3.33	4.17	5.00	6.67	8.33	10.00	11.67	13.33	15.00	16.67	20.00
81	1.69	2.53	3.38	4.22	5.06	6.75	8.44	10.13	11.81	13.50	15.19	16.88	20.25
82	1.71	2.56	3.42	4.27	5.13	6.83	8.54	10.25	11.96	13.67	15.38	17.08	20.50
83	1.73	2.59	3.46	4.32	5.19	6.92	8.65	10.38	12.10	13.83	15.56	17.29	20.75
84	1.75	2.63	3.50	4.38	5.25	7.00	8.75	10.50	12.25	14.00	15.75	17.50	21.00
85	1.77	2.66	3.54	4.43	5.31	7.08	8.85	10.63	12.40	14.17	15.94	17.71	21.25
86	1.79	2.69	3.58	4.48	5.38	7.17	8.96	10.75	12.54	14.33	16.13	17.92	21.50
87	1.81	2.72	3.63	4.53	5.44	7.25	9.06	10.88	12.69	14.50	16.31	18.13	21.75
88	1.83	2.75	3.67	4.58	5.50	7.33	9.17	11.00	12.83	14.67	16.50	18.33	22.00
89	1.85	2.78	3.71	4.64	5.56	7.42	9.27	11.13	12.98	14.83	16.69	18.54	22.25
90	1.88	2.81	3.75	4.69	5.63	7.50	9.38	11.25	13.13	15.00	16.88	18.75	22.50
91	1.90	2.84	3.79	4.74	5.69	7.58	9.48	11.38	13.27	15.17	17.06	18.96	22.75
92	1.92	2.88	3.83	4.79	5.75	7.67	9.58	11.50	13.42	15.33	17.25	19.17	23.00
93	1.94	2.91	3.88	4.84	5.81	7.75	9.69	11.63	13.56	15.50	17.44	19.38	23.25
94	1.96	2.94	3.92	4.90	5.88	7.83	9.79	11.75	13.71	15.67	17.63	19.58	23.50
95	1.98	2.97	3.96	4.95	5.94	7.92	9.90	11.88	13.85	15.83	17.81	19.79	23.75
96	2.00	3.00	4.00	5.00	6.00	8.00	10.00	12.00	14.00	16.00	18.00	20.00	24.00
97	2.02	3.03	4.04	5.05	6.06	8.08	10.10	12.13	14.15	16.17	18.19	20.21	24.25
98	2.04	3.06	4.08	5.10	6.13	8.17	10.21	12.25	14.29	16.33	18.38	20.42	24.50
99	2.06	3.09	4.13	5.16	6.19	8.25	10.31	12.38	14.44	16.50	18.56	20.63	24.75
100	2.08	3.13	4.17	5.21	6.25	8.33	10.42	12.50	14.58	16.67	18.75	20.83	25.00

# ORDERING INFORMATION

## Chain Components

### Connecting Link Spring Lock Type

The two pins and one link plate are furnished assembled. The standard coverplate is designed for a slip-fit on the pins. It is held in place by a flat spring-steel lock, split at one end to permit installation in grooves at the end of each pin.

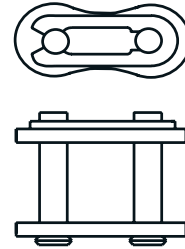

### Roller Link

Standard for all sizes of roller chains. They are furnished as complete roller link assemblies. The two bushings are press-fit in each of the link plates. The same roller links are used for single and multiple strand chains.

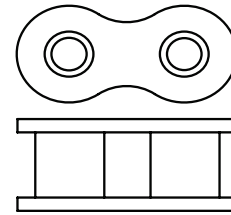

### Single-Pitch Offset Link Slip-Fit Type

This link is furnished with slip fit pin unassembled in the offset link plates. The flat milled on one end of the pin prevents it from turning in the link plate.

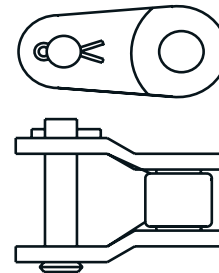

### Connecting Link Cotter Pin Type

The two pins and one link plate are furnished assembled. The coverplate is slip-fit on the pins. Press-fit connecting links are available upon special request.

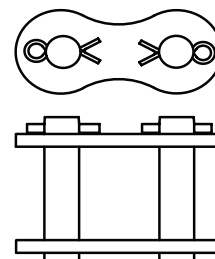

# ORDERING INFORMATION

Basic Information needed to order all chain.

- Quantity
- Catalog number
- Type
- Riveted or cottered when optional
- Chain length

If you have any questions, please do not hesitate to contact one our Inside Sales or Sales Engineering staff members, we are ready to serve you.

## Headquarters

402 Kentucky Avenue  
P.O. Box 7045  
Indianapolis, IN 46207  
1-317-638-6431  
1800-872-4246  
1-800 US CHAIN

## Service Centers:

**Dallas, Texas**  
877-453-9128 (toll free)  
214-631-2374 (fax)

**Sacramento, California**  
877-453-9127 (toll free)  
916-372-5801 (fax)

**New Castle, United Kingdom**  
44-(0)191-414-8822  
44-(0)191-414-8877 (fax)

**Brampton, Ontario, Canada**  
905-455-6969  
905-455-6061 (fax)

Chain-5 pitches long, roller link each end.

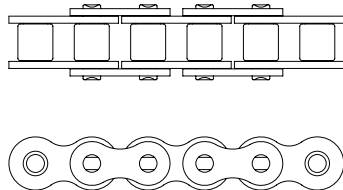

Chain-9 pitches long, with bent attachments, both sides of chain, every pitch.

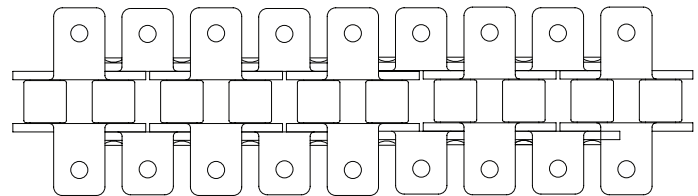

Chain-6 pitches long, including connecting link.

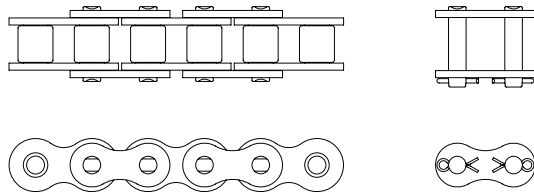

Chain-9 pitches long, with straight attachments, every pitch.

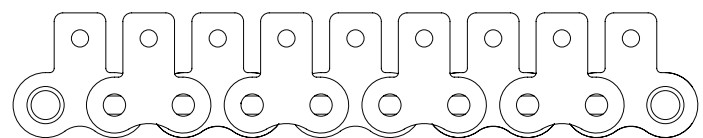

Chain-24 pitches long, riveted endless.

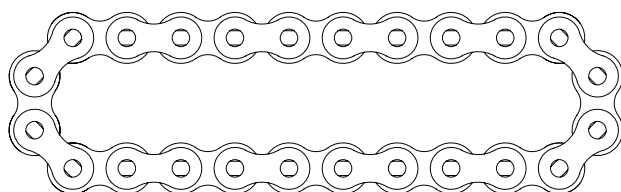

Chain-9 pitches long, with all pins extended.

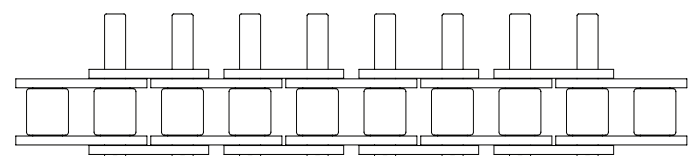

RSC **SAPPHIRE**<sup>®</sup>  
ROLLER CHAIN

At Sapphire Roller Chain, our bottom line is competitive prices and consistent quality products inspected to meet your price-sensitive import chain demands, with the service you expect and deserve.



MOTORCYCLE



DRIVE CHAIN



AG CHAIN



402 Kentucky Avenue  
P.O. Box 7045, Indianapolis, IN 46207  
1-317-638-6431 1-800 US CHAIN (872-4246)  
[diamondchain.com](http://diamondchain.com)