

PUMP OPTIONS	FEATURE OPTIONS	SPRAY OPTIONS
	TWIST LOCK	NARROW SPRAY
180 mcl standard spray	CHILD RESISTANT TWIST LOCK	WIDE SPRAY
	DELUXE CHILD RESISTANT LOCK	
180 mcl up and down spray		

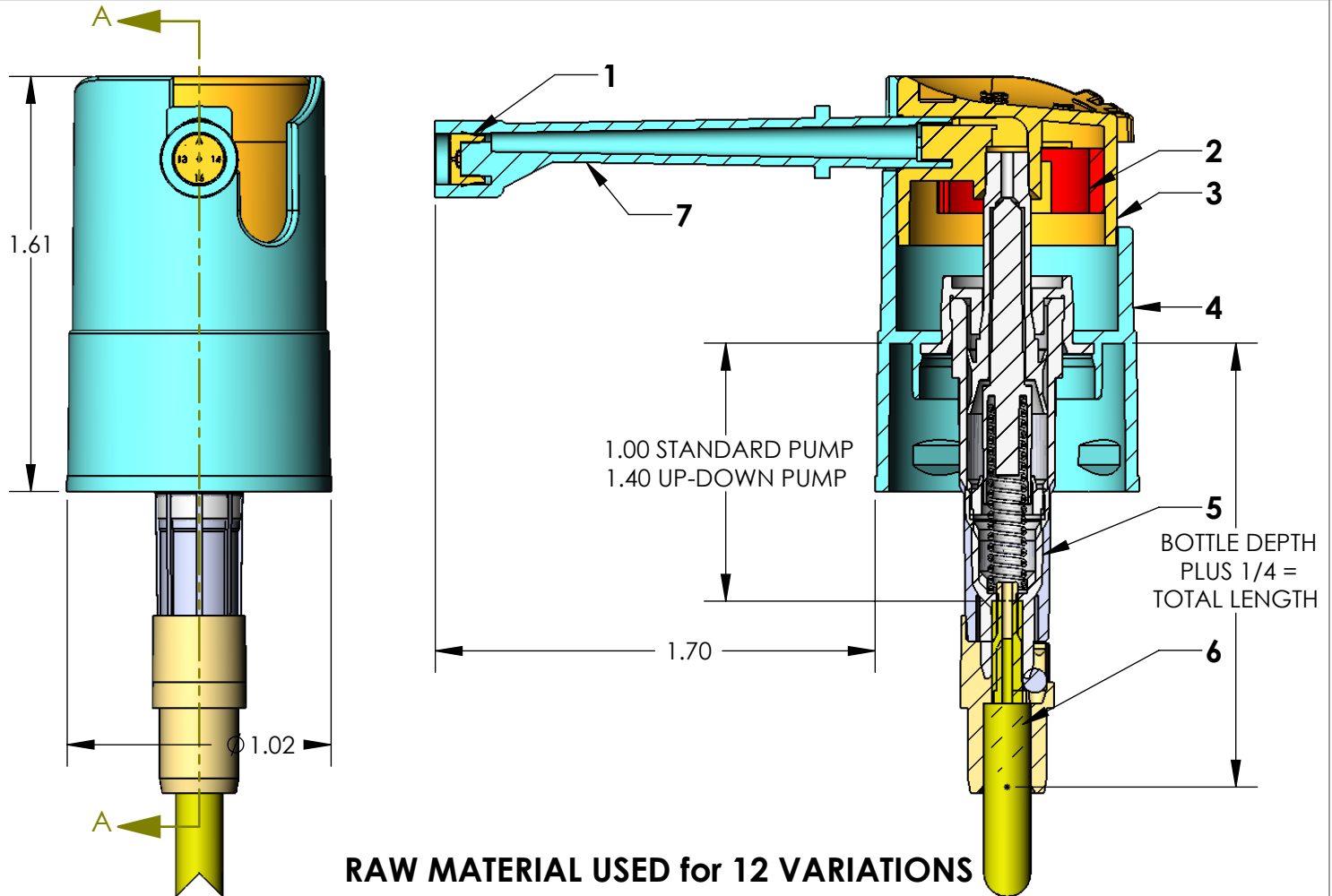

RAW MATERIAL USED for 12 VARIATIONS

ITEM	NAME	PART #	MATERIAL
1	INSERT	PE001, PE002	ACETAL
2	CR BUTTON	MT-001	ACETAL
3	ACTUATOR	MA007, MA012, MA014	HDPE, ACETAL
4	CAP	MB014	POLYPRO
5	PUMP	SEE PUMP SHEET	SEE PUMP SHEET
6	DIP TUBE	PT001, PT003, PT005, PT007	LDPE, HDPE
7	EXTENDER	ME001-000	HDPE, ACETAL

<p>PROPRIETARY AND CONFIDENTIAL THE INFORMATION CONTAINED IN THIS DRAWING IS THE SOLE PROPERTY OF Packaging Concepts Assoc., LLC. ANY REPRODUCTION IN PART OR AS A WHOLE WITHOUT THE WRITTEN PERMISSION OF Packaging Concepts Assoc., LLC IS PROHIBITED.</p>	DIMENSIONS ARE IN INCHES TOLERANCES: FRACTIONAL ± ANGULAR: MACH ± BEND ± TWO PLACE DECIMAL ± THREE PLACE DECIMAL ±		NAME	DATE	<p>PACKAGING CONCEPTS ASSOC., LLC BOYNTON BEACH, FLORIDA</p> <p>SNAP-ON SPRAYER AC940 EXTENDED SPRAY STANDARD OR CHILD RESISTANT</p>	
	MATERIAL		DRAWN	HWD		5/21/16
	FINISH		CHECKED			
	NEXT ASSY USED ON		ENG APPR.			
APPLICATION	DO NOT SCALE DRAWING		MFG APPR.			
			Q.A.			
			COMMENTS:			
			SIZE	DWG. NO.	REV.	
			A	AC918	A	
			SCALE: 1:1	WEIGHT:	SHEET 1 OF 1	