

Seal housing

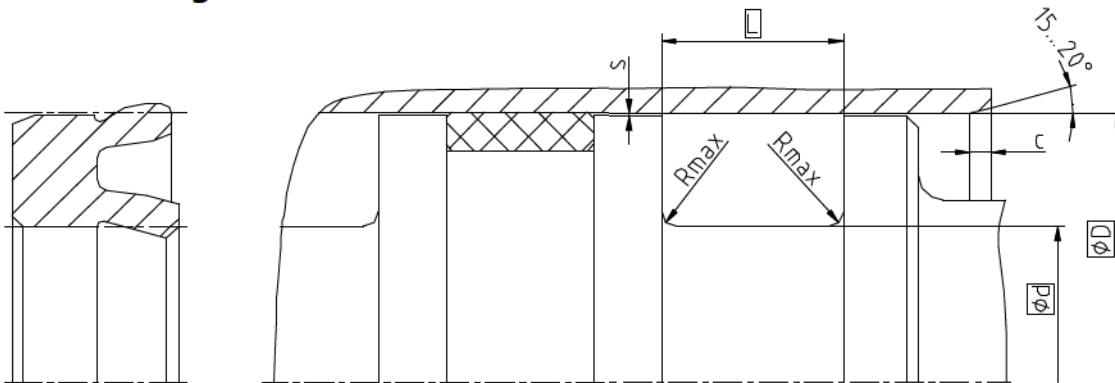

Surface roughness	Rtmax	Ra
Sliding Surface	≤ 2,5 µm	0,1...0,5 µm
Bottom of groove	≤ 6,3 µm	≤ 1,6 µm
Groove face	≤ 15 µm	≤ 3 µm

Ordering dimensions...□

Bearing area: 50...95% and a cutting depth of 0,5xRz based on Cref = 0%

Standard dimensions

ØD H9	Ød h10	L +0,2	Rmax	c	s*
≥ 13 ... ≤ 25	D - 8	6,0	0,4	3,5	0,33
> 25 ... ≤ 50	D - 10	7,0	0,4	4,0	0,37
> 50 ... ≤ 75	D - 12	8,0	0,4	4,5	0,42
> 75 ... ≤ 150	D - 15	10,0	0,4	5,0	0,46
> 150 ... ≤ 300	D - 20	12,0	0,4	6,0	0,54
> 300 ... ≤ 500	D - 25	18,0	0,4	8,5	0,61
> 500 ... ≤ 750	D - 30	20,0	0,4	10,0	0,67
> 750	D - 40	26,0	0,4	13,0	0,67

* Extrusion gap applies to a temperature of 70 °C, higher temperatures require lower values.

Operating parameters

Sealing material	Temperature	max. speed	max. pressure
ECOPUR®	-30 °C...+110 °C	1 m/s	25 bar (2,5 MPa)
H-ECOPUR™	-20 °C...+110 °C		
S-ECOPUR™		2 m/s	
T-ECOPUR™	-50 °C...+110 °C	1 m/s	
G-ECOPUR™	-30 °C...+110 °C		

The stated operation conditions represent general indications. It is recommended not to use all maximum values simultaneously. Surface speed limits apply only to the presence of adequate lubrication film.

Ordering example

K05-P, D=100mm, d=85mm, L=10mm, ECOPUR®

Piston Seal K05-P
Profile

100 x 85 x 10
D x d x L

ECOPUR®
Sealing material