

Seal housing

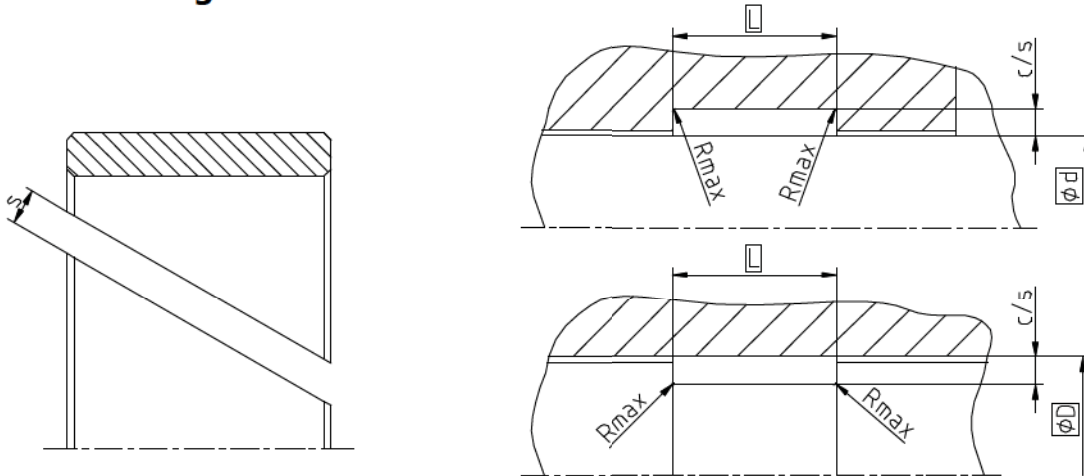

Sealing material	PU/Elastomers		PTFE	
	Rtmax	Ra	Rtmax	Ra
Sliding Surface	≤ 2,5 µm	0,1...0,5 µm	≤ 2 µm	0,05...0,3 µm
Bottom of groove	≤ 6,3 µm	≤ 1,6 µm	≤ 6,3 µm	≤ 1,6 µm
Groove face	≤ 15 µm	≤ 3 µm	≤ 15 µm	≤ 3 µm

Ordering dimensions...□

Bearing area: 50...95% and a cutting depth of 0,5xRz based on Cref = 0%

Standard dimensions

inside dynamic surface		outside dynamic surface		c/s	L +0,2	Rmax
Ød f8	ØD H9	ØD H9	Ød f8			
≥ 6 ... < 30	d + 3	≥ 6 ... < 30	D - 3	1,5	4	0,3
≥ 30 ... < 50	d + 3	≥ 30 ... < 50	D - 3	1,5	5,6	
≥ 50 ... < 100	d + 5	≥ 50 ... < 100	D - 5	2,5	9,7	
≥ 100 ... ≤ 800	d + 5	≥ 100 ... ≤ 800	D - 5	2,5	15	
> 800	d + 8	> 800	D - 8	4	25	

* cutting gap s : values depend on material and temperature. For detailed information please refer to the profile description.

Operating parameters

guiding material	Temperature	max. speed	Specific load ²
SKF ECOFLON 2	-200 °C...+200 °C	4 m/s	3,0 N/mm ²
SKF ECOFLON 3	-200 °C...+200 °C	5 m/s	4,5 N/mm ²
SKF ECOFLON 60% Bz.	-200 °C...+200 °C	5 m/s	7,5 N/mm ²
SKF ECOTAL¹	-50 °C...+100 °C	4 m/s	25 N/mm²
SKF ECOMID	-40 °C...+100 °C	4 m/s	25 N/mm ²
SKF ECOTEX	-40 °C...+130 °C	4 m/s	90 N/mm ²

The stated operation conditions represent general indications. It is recommended not to use all maximum values simultaneously. Surface speed limits apply only to the presence of adequate lubrication film.

¹ ≤ Ø260mm: SKF ECOTAL ; > Ø260mm: SKF ECOMID

² Depending on temperature and allowed compression. Detailed information see profile description.

Ordering example

F01, d=100mm, D=105mm, L=2,5mm, SKF ECOTAL

Guide Ring F01
Profile

100 x 105 x 2,5
d x D x L

SKF ECOTAL
guiding material