

Piston seals

Seal housing

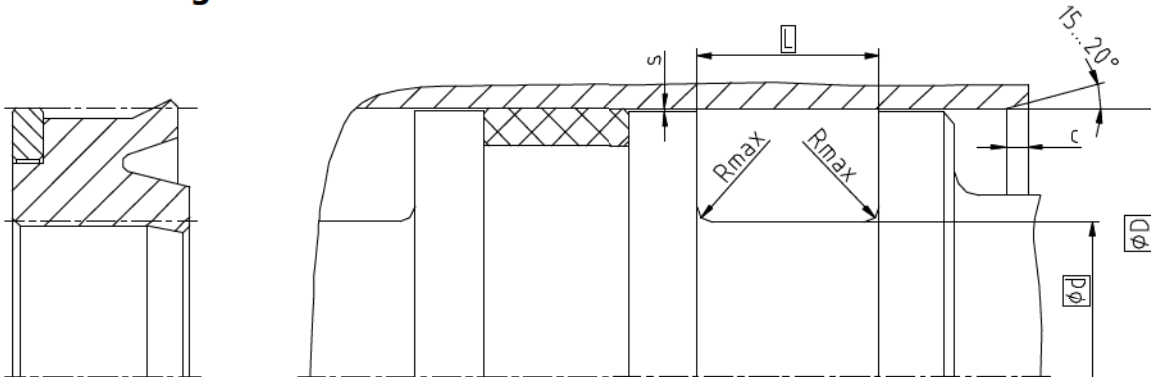

Surface roughness	Rtmax	Ra
Sliding Surface	≤ 2,5 µm	0,1...0,5 µm
Bottom of groove	≤ 6,3 µm	≤ 1,6 µm
Groove face	≤ 15 µm	≤ 3 µm

Ordering dimensions...□

Bearing area: 50...95% and a cutting depth of 0,5xRz based on Cref = 0%

Standard dimensions

ØD H9	Ød h10	L +0,2	Rmax	c	max. radial extrusion gap s*			
					20 bar	100 bar	400 bar	700 bar
≥ 13 ... ≤ 25	D - 8	6,0	0,4	3,5	0,80	0,80	0,30	0,04
> 25 ... ≤ 50	D - 10	7,0	0,4	4,0	1,00	1,00	0,37	0,04
> 50 ... ≤ 75	D - 12	8,0	0,4	4,5	1,25	1,24	0,42	0,05
> 75 ... ≤ 150	D - 15	10,0	0,4	5,0	1,50	1,47	0,46	0,05
> 150 ... ≤ 300	D - 20	12,0	0,4	6,0	2,00	1,77	0,54	0,06
> 300 ... ≤ 500	D - 25	18,0	0,4	8,5	2,5	2,06	0,62	0,06
> 500 ... ≤ 750	D - 30	20,0	0,4	10,0	3,00	2,43	0,76	0,06
> 750	D - 40	26,0	0,4	13,0	3,00	2,43	0,76	0,06

* Extrusion gap applies to a temperature of 70 °C, higher temperatures require lower values.

Operating parameters

Sealing material	Backup ring	Temperature	max. speed	max. pressure ¹
ECOPUR®	SKF ECOTAL SKF ECOMID ²	-30 °C...+100 °C	0,5 m/s	700 bar (70 MPa)
H-ECOPUR™		-20 °C...+100 °C		
S-ECOPUR™		-20 °C...+100 °C	0,7 m/s	
T-ECOPUR™		-40 °C...+100 °C	0,5 m/s	
G-ECOPUR™		-30 °C...+100 °C		

The stated operation conditions represent general indications. It is recommended not to use all maximum values simultaneously. Surface speed limits apply only to the presence of adequate lubrication film.

¹ Pressure ratings depend on the size of the extrusion gap.

² ≤ Ø260mm: SKF ECOTAL ; > Ø260mm: SKF ECOMID

Ordering example

K02-P, D=100mm, d=85mm, L=10mm, ECOPUR® / SKF ECOTAL

Piston Seal K02-P
Profile

100 x 85 x 10
D x d x L

ECOPUR® / SKF ECOTAL
Sealing material / Backup ring